



Additive manufacturing of composite materials by FDM technology: A review

Andrei Danut Mazurchevici, Dumitru Nedelcu* & Ramona Popa

^aGheorghe Asachi, Technical University of Iasi, Blvd Mangeron No. 59A, 700050, Iasi, Romania

Received: 31 October 2018; Accepted: 26 July 2019

The additive manufacturing known also as “3D printing” or “rapid prototyping” is a present manufacturing method (compared to classic manufacturing methods) where layers of material are deposited at a time (successively) until a finished product is obtained. Depending on the phenomenon, material (in solid, liquid or powder state) used by the 3D printing equipment, a solid part, can be achieved using processes as: binder jetting, extrusion, material jetting, direct energy, vat photo-polymerization and powder bed fusion. In the present paper, we have summarized some knowledge regarding the 3D printing technologies, fused deposition modeling (FDM) prototyping method, and different types of test regarding PLA material properties (tensile test, flexural test). The FDM technology has registered benefits as cost, product quality, functionality and manufacturing time, continuously optimized and adopted by more and more companies, research institutes and consumers.

Keywords: Smart forming, 3D printing, FDM technology, PLA material properties

1 Introduction

The manufacturing techniques can be categorized in three groups as: formative manufacturing (injection molding, casting, stamping and forging), manufacture with layer removal (CNC, drilling and turning) and additive manufacturing (3D printing). The first two of these are traditional manufacturing technologies and in the last decades offers fewer advantages compared with the additive manufacturing technology. The 3D printing allows to be obtained a complex design quickly, with high accuracy, low costs and from a functional material, chosen according to demand^{1, 2}. Three dimensional printing has become during the past years an incredibly useful tool for rapid prototyping in manufacturing industry. The rapid prototyping is not a new manufacturing technology but has a low cost of equipment. The additive manufacturing can be divided into several categories, depending on the deposition method used by the printing technology (Fig. 1). Vat Photo-polymerization which includes prototyping technologies such as stereo lithography (SLA), direct light processing (DLP), continuous DLP (CDLP), this one use plastic material to realize fine-cut parts and a smooth surface in order to obtain jewelry, dental and medical applications; powder bed includes technologies such

as fusion multi jet fusion (MJF), direct metal laser sintering (DMLS), selective laser sintering (SLS), electron beam melting (EBM) and selective laser melting (SLM),- use plastic and metal powders to obtain complex geometry parts; Material Extrusion is represented by fused deposition modeling (FDM)- use melted plastic to get quick parts; Material Jetting comprise material jetting, nano particle jetting, drop-on-demand (DOD) - use plastic, metallic and wax materials for realistic prototypes, delivering excellent detail, high precision and the ability of multiple colors print in a single printed part; binder jetting - use metal, gyps and sand to obtain architectural designs; direct energy cover the deposition laser engineered net shape (LENS) and electron beam additive manufacture (EBAM) - use metallic material ideal for repairing or adding materials to existing components^{1, 2}. Table 1 list the main advantages and disadvantages of the most commonly used 3D printing technologies.

2 FDM Technology - Brief Presentation

Considering the strengths and weaknesses of the main rapid prototyping methods presented inside of Table 1, the project research will use the FDM technology. Further, a detailed list of the process advantages and disadvantages is given in Table 2.

Fused deposition modeling (FDM) a term trademarked by Stratasys, known in the literature also

*Corresponding author (E-mail: nedelcu1967@yahoo.com)

Additive manufacturing technologies

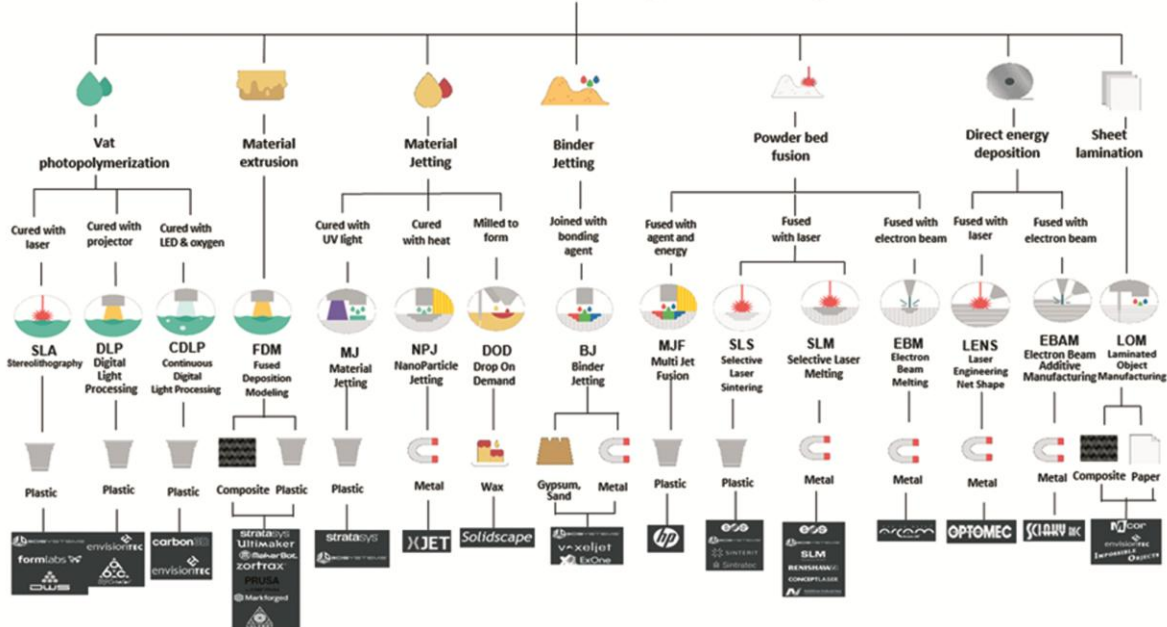

Fig. 1 — Scheme of all additive manufacturing technologies².

Table 1 — Overall characterization of the main printing methods¹⁻⁴.

Technologies`	Printing scheme	Physico-chemical processes	Strengths & Weaknesses	Material	Applications	Dimensional precision
SLA		cured with laser	+ high quality surface finish; +high precision; +transparent; + flexible material; + fine feature details; + market leader; + large part size; + wide product; - brittle, not suitable for mechanical parts; -post processing, messy liquids.	photopolym er resins (thermosets)	injection mold like polymer prototype, jewelry, dental and medical application, hearing aids	±0.5% (lower limit: ±0.15mm)
SLS		fused with laser (sintering)	+ high precision; + functional parts; + good mechanical properties; + complex geometries; + market leader; + large part size; - longer lead times; - higher cost then FDM functional applications; - size and weight.	thermoplast ic powder	functional polymer parts, complex ducting (hole low design), low run part production	±0.3% (lower limit: ±0.3mm)

(Contd.)

Table 1 — Overall characterization of the main printing methods¹⁻⁴. (Contd.)

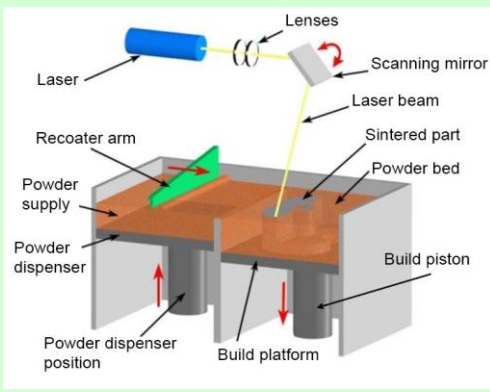
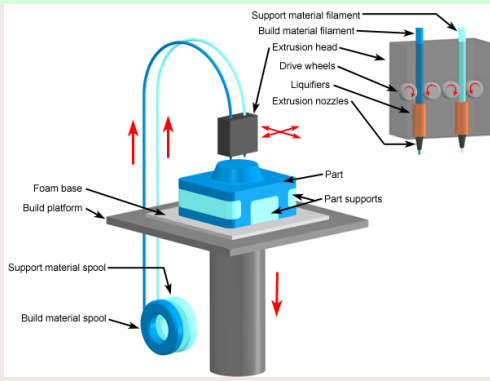
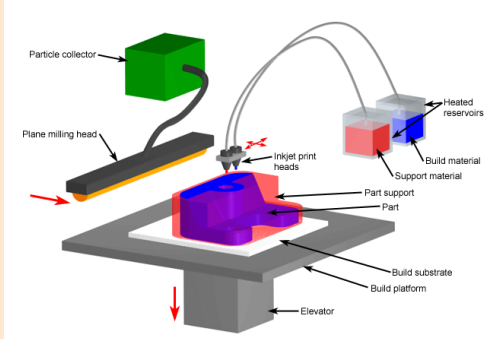
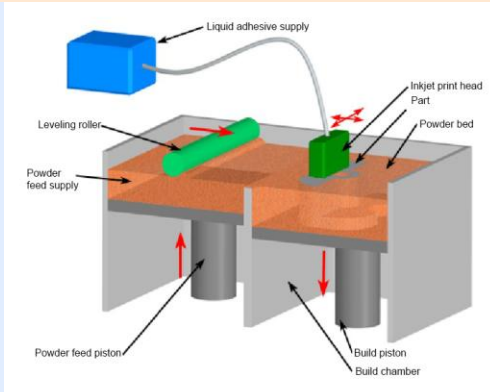
SLM		fused with laser	<ul style="list-style-type: none"> + strongest functional parts; + complex geometries; - small build sizes; - highest price point of all technologies. 	metal powder	functional metal parts (from aerospace and automotive industry's), medical and dental applications	±0.1mm
FDM		melted and UV cured	<ul style="list-style-type: none"> + rapid prototyping; + low cost; + functional parts (noncommercial); - limited dimensional accuracy for small parts; - print layers likely visible on surface; - low printing speed. 	thermoplastic filament	Electrical housings/enclosures, jigs and fixtures, investment casting patterns	±0.5% (lower limit: ±0.5mm)
Mat. Jetting		cured with UV light	<ul style="list-style-type: none"> +high temperature; +best quality surface finish; +high precision; +transparent; + color printing and multi-material available; - brittle, not suitable for mechanical parts; -higher cost than SLA for visual proposes. 	thermoset photopolymer resins	Prototypes with different colors; Prototype of injection molding; Medical models; Low run injection molds.	±0.1mm
Binder Jetting		joined with bonding agent	<ul style="list-style-type: none"> + low cost; + large build volumes; + functional metal parts; +quality surface finish; +high precision; - mechanical properties not as good as metal powder bed fusion; - speed limited; - parts small dimensions. 	sand, gypsum, metal powder	functional metal parts, full color modes, sand casting, architectural models, packaging, ergonomic verification	±0.2mm (metal) or ±0.3mm (sand)

(Contd.)

Table 1 — Overall characterization of the main printing methods¹⁻⁴. (Contd.)

LENS		fused with electron beam	<ul style="list-style-type: none"> + build fully dense shapes; + used in part reconditioning; + desirable metallurgical properties; - lack of a different material for support structures; - post-print machining. 	metal powder	turbine blades, complex metallic implants, samples for medical implant application, parts of the defense industry	±0.02-0.4mm
LOM		thermalizes and hardening polymers	<ul style="list-style-type: none"> + large part size; + good for large casting; + very inexpensive material (paper); + without impact on health; + high printing speed and good tolerances; + environmentally friendly; + high handling strength; - part stability; - smoke; - surface finish; - dimensional accuracy; - difficulty in producing hollow parts; - post-processing operations. 	Composite, paper	automotive parts; concept verification; silicone-rubber injection tools; investment casting patterns; direct use; fit-check;	±0.2mm (composite) or ±0.4mm (paper)

Table 2 — Detailing the advantages and disadvantages of FDM technology^{3,4}.

Advantages

- does not use toxic materials, which allows the use of equipment even in office spaces;
- simple post-processing operations: it takes only a few minutes (up to a quarter of hour) to remove the building support;
- some 3D printers that are using FDM technology are very cheap;
- friendly, silent and secure technology;
- objects and functional parts can be produced;
- uses a fairly wide range of materials;
- extremely affordable price for 3D printers (kits and assembled models), materials used to print the components of the 3D printer in reality, and also supplies (plastic filament rollers);
- a simple production technology, which means ease of 3D printers use;
- hole parts (bottles, cans) can be built quickly;
- compared to other processes that are using powdered or liquid materials, the filament is cleaner and easier to change.

Disadvantages

- the main drawback of FDM model is the low construction speed for models with high geometric complexity;
- the parts are not resistant in the vertical direction;
- the precision of the piece depends on the thickness of the filament;
- the possibility of small surface defects caused by the imperfect bonding of the layers;
- low waterproofness;
- Low resolution and accuracy for small parts and fine detail (microns).

as fused filament fabrication (FFF), represents the largest installed base of additive manufacturing technology which is part of the extrusion group. In fused deposition modeling technology, different parts are built using strings of a solid thermoplastic material which is selectively deposited layer-by-layer in a pre-determined path¹⁻⁵.

2.1 Phases of FDM Process

The phases are shown in Fig. 2. Forwards, the process stages are explained and also are presented the vulnerabilities (for each step separately) that can affect the final piece.

2.1.1 Design

This step refers to the computer-aided design model and analysis with finite element. A group of design engineers use a CAD package (commonly available) to get a product model based on the desired properties, dimensions and functionalities. After this, the 3D model generated by the CAD software is analyzed with finite element. Also in this stage are performed different simulations that requires knowledge of the common properties of the used material such as: tensile strength, elastic modulus, compressive strength, *etc.* The obtained simulation results will possible guide revisions of the first model up to obtain an optimal model which satisfies all the necessary requirements^{6,7}.

2.1.2 Manufacturing

In this step the model is sent to the software of FDM Quickslice using the STL format, thus occurs AM deviation from the traditional manufacturing. The STL format makes a tessellation of the designed model in a pattern made from repeated regular polygons (triangles). Once with the end of this step the model is horizontally sliced into many thin sections. The FDM software will use these sections that represents the 2D (two dimensional) contours of the original 3D (three-dimensional) part to generate the plan of the process which commands the FDM equipment's hardware. The slicing step (in case of

this technology) involves where is necessarily to use support material (for all the structure that has less than 45° overhang angle from horizontal) otherwise more than half of one layer will be hang over the contour below it. Also it can affect considerable (even fatal) the shape and the performance of the final part. The slicer program allows to define the 3D printer build parameters, determined the models position in the printed volume and the layer height as well. The STL file is converted in G-code (target-machine-specific tool path code) and the printer head movement will be encoded on X, Y, Z directions. After the G-code establishment this one is loaded in to the printer and from this point begins effectively the 3D part manufacturing^{6,7}.

The first step in order to prototype a part by using FDM fabrication technology is the loading of chose thermoplastic filament spool into the printer equipment (Fig. 3). The nozzle is heated (with a resistance) until the desired temperature is reached, the filament is pushed through extrusion head where the material is semi-melted. It follows the extrusion of the material and its deposition on a given path, layer-by-layer (Fig. 4). The layer it cooled and solidified normally (at room temperature) or it can opt for accelerated cooling through cooling fans which are attached on the extrusion head. Multiple passes are required in order to fill an area (the process is similar to the rectangle coloration with a marker) In the moment of a complete layer there are two possibilities: moves down of build platform or moves up of the extrusion head, after this follows a new deposited layer until the object it is finished.

The equipment deposits semi-melted thermoplastic in a directional way that results in parts with an

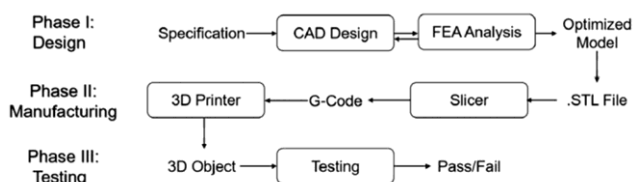

Fig. 2 — Scheme of the FDM manufacturing process⁶.

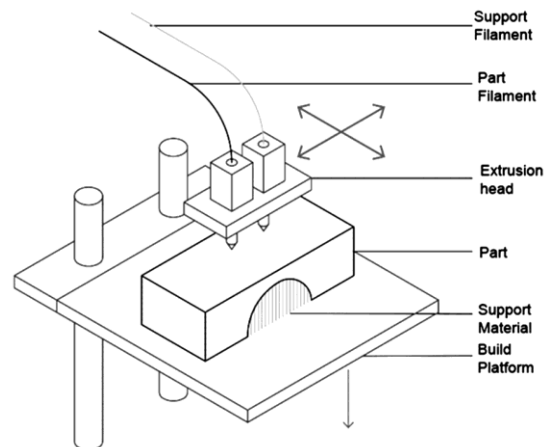

Fig. 3 — The working diagram of the FDM printing process¹.

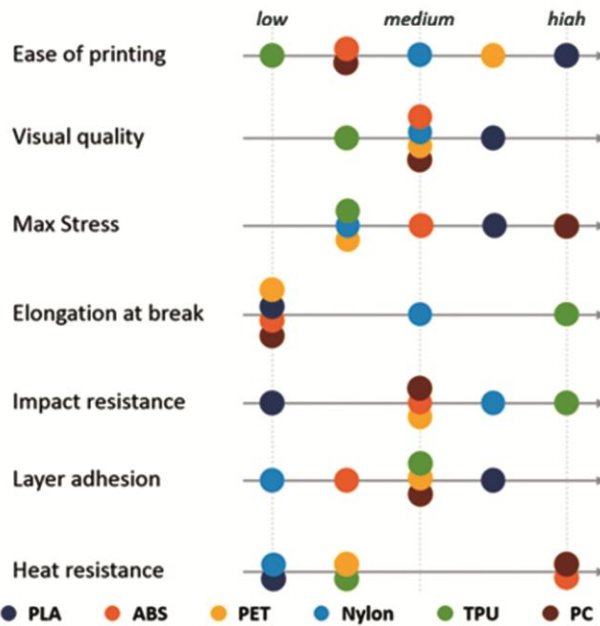

Fig. 4 — The obtained results for the compared thermoplastic materials^{2, 9}.

anisotropic behavior. The post processing and finishing stage (removal of support, sanding, cold welding, gap filling, polishing, priming and painting, vapor smoothing, dipping, epoxy coating, metal plate) are performed before the solid part to be tested.

2.1.3 Testing

The prototype obtained by FDM is subjected to physical and mechanical testing to obtain information concerning the performance of this one. The quality control or the validation of a part can have destructive or nondestructive (NDT) nature. The NDT tests can be performed to a randomly chosen part or to all obtained parts depending on the required reliability and the uniqueness of the parts. Ultrasonic imaging and x-ray computed tomography (x-ray CT) are non-destructive testing methods (the quality control) which varies greatly in terms of time investment and resolution. In the validation of compliance with different industry or government standards are used experiments designed or traditional material testing procedures. The testing procedure in case of AM by FDM technology is comparable to the procedure from traditional manufacturing, but the tests and the obtained results interpretations become more complicated with the part complexity increasing^{6, 7}.

2.2 Materials Used in the FDM Printing Method

The additive manufacturing use mostly, common materials (plastic, metal, sand, wax, gyps, *etc.*) that

are found also in the traditional processing technologies. Before printing a prototype, it has to be selected a printable material, this is difficult decision do to the vast possibility. Along with the rapid prototyping evolution occurs the concern regarding the effects of 3D printing (parts, scraps of material) on the environment. Taking into account the growing of this topic, the attention of researchers begins to be more focused on the negative impact of the carbon and waste footprints. Thus, biodegradable, recyclable, compostable materials have been developed to pursue the idea of "eco-friendly" material⁸. The new product has to be competitive from technological, economical point of view and also to provide superior properties towards to common materials.

Nevertheless, the rapid prototyping materials market is dominated by no biodegradable materials, especially because of their low cost. The materials are usually graded on 3 directions, mechanical performance, process and quality but the below graph presents the key decision criteria (easy of print, visual quality, max stress, elongation at break, impact resistance, layer adhesion (isotropy) and heat resistance) for choosing a print material¹. A brief presentation of the research results regarding the material properties for the main pure polymers used in FDM technology in the last years (PLA (polylactic acid), PC (polycarbonate), PET (polyethylene terephthalate), TPU (flexible) (thermoplastic polyurethane), ABS (acrylonitrile butadiene styrene) and Nylon 6, is displayed in Fig. 4.

Summaries of the results: PLA is a biodegradable (made from bioresearches) thermoplastic which in FDM printing revile high stiffness, good details, affordable, but unsuitable for high temperatures. ABS is a commodity plastic, with improved thermal and mechanical properties (excellent impact strength) in comparison with PLA material. PET is a recyclable slightly softer polymer with better mechanical properties that of PLA and ABS but with weight bigger that of these ones. The material has an excellent moisture and chemical resistance. The major drawback is its weight bigger that of PLA and ABS. Nylon 6 possesses great mechanical properties (high strength, best impact resistance for a non-flexible filament) and high abrasion and chemical resistance. The material issue is the adhesion of layers. TPU (flexible) is mainly used for flexible parts, but can be use also for other applications do to the very high impact resistance and good resistance to oil and grease. PC can be sterilized. PC represents the

strongest material of all six, is a good alternative to ABS as the main properties are quite similar^{1,9,10}.

3 Applications of 3D Printing

Generally, the main industrial applications for 3D printing technologies are as follows:

- Dental and medical industries:
 - parts of the human body - a fully functional liver tissue; a human ear; facial, bone or limb replacement (not only for humans but also for animals);
 - implant and device for medical use: titanium pelvis, titanium lower jaw, plastic tracheal splint;
 - biotech - human tissue replacement;
 - building implants after a certain shape - for example dental or bone implants;
 - skeletons and corpses replicas - in Belgium, the mummy of Pharaoh Tutankhamon was created a natural-size replica with 3D technology; fetal replicas - Brazilian or Japanese companies offer the opportunity to create replicas of fetuses still in the uterus. Their purpose is only a decorative one¹¹.
- Construction (AEC) - construction components or entire buildings - The University of Southern California, in collaboration with NASA, printed structures with the purpose of using them as housing for the Moon's population, but research also includes printed houses for terrestrial living.
 - Food: to prepare culinary items with a complex structure or form: shells, cakes and banana-like gelatin, chocolate and candy, crackers, pasta and pizza. NASA's research is also done to print other types of food, from meat to fast food. The nature of food texture is the main problem in food printing, for instance, foods that are not so strong in order to be filed and are not suitable for rapid prototyping¹¹.
 - Automotive industry - parts for machine building - complete turbocharger assemblies, side-mirror internals, titanium exhaust components and air ducts. The University of Southampton made an electric car and an unmanned aerial vehicle, both functional, created entirely using 3D printing;
 - Architecture: miniature creation of an architectural model or layouts;
 - Industry: creation of small objects with a complex form or structure, the rapid prototyping of some object models;
 - Archeology: reconstruction of artifacts and fossils;
 - Criminology: recreation of damaged or incomplete physical objects;

-Cinematography: creating masks or personalized suits;

-In the handmade domain: creation of decorative objects¹¹;

-In the personal or household domain: creating personal or household items containing personalized items.

-Education and research – For the manufacture of different components used in experimental research, such as vacuum components and magnetic shielding, 3D printing technology can be used and these can be compared with products obtained by traditional technologies. Recreation of fossils and historical artifacts by students is possible by 3D printing without damaging the collections;

-Aerospace: spare parts for planes; turning extraterrestrial soil into printable parts;

-Military: firearms - plastic guns;

-Computers and robots - laptops and other computers and cases;

-Industrial art and jewelry - products such as personalized models of art and dolls, or as consumable art, such as 3D printed chocolate; jewelry;

-Fashion - footwear and dresses, bikinis, eyewear¹¹;

-3D selfies –or mini-me figurines, 3D portraits and figurines.

From the FDM technology point of view, the main industrial applications are: resistant parts and subassemblies for functional testing (customized parts for Formula 1 equipment)¹¹, conceptual design, presentation and marketing models, details parts of food or medical applications, plastic subassemblies for high temperature applications, very small series productions, molds, prototyping of matrices (structural scaffolds, medical implants) for medical applications in tissue engineering¹², bio-medical implant (hip)¹³, rapid prototyping of small pieces and tools, architectural models^{14, 15}, toys (small series for hospitals, kindergartens or customized products for clients with special needs in hospitals)¹⁶, *etc.*

4 Experimental Results

The main results from the specialized literature relating to 3D printing of plastic and biodegradable materials are presented in the following. The results are for PLA material with reference to mechanical, thermal and structural properties.

4.1 The Effect of Process Parameters on PLA Mechanical Properties

The aim of this research was focus on samples mechanical performance obtained by 3D printing

from PLA. In this study was used filament of *PLA SMARTFIL* produced by Smart Materials 3D Company¹⁷ and 1.75mm diameter value. Table 3 presents the main PLA mechanical properties in case of printing by FDM^{18, 19}.

4.1.1 Experimental methodology

In order to obtain samples from PLA material was used a WitBox 3D equipment manufactured by the BQ Company²⁰. The D790²¹ and ASTM D638²² methods were used inside of these research for the flexural and tensile tests. The sample dimensions are shown in Fig. 5.

The mechanical properties of manufactured samples by Fused Deposition Modeling method it's up to the selection of process parameters. Table 4 presents the process parameters took into account in this research. It was used three types of sample orientations (Fig. 6a), such as: flat (F), on-edge (O) and upright (U)²³.

In the following figures the results of different studies on the effect of orientation type, thickness of

layer and filling rate on the PLA samples mechanical properties are presented.

Thus, Fig. 7 shows the strain-stress curves for the tensile test samples taking into account two layer thicknesses (0.06 mm and 0.24 mm) and two filling speeds (20 mm/s and 80 mm/s).

The strain-stress curves for bending tests taken into account the same layer thicknesses as in case of tensile tests (0.06 mm and 0.24 mm) and the same filling speeds (20 mm/s and 80 mm/s) are shown in Fig. 8. The tensile stress versus the thickness of the layer at different filling speeds (20, 50, 80 mm / s) is shown in Fig. 9a and the tensile stress according to the type of print orientation is shown in Fig. 9b.

The bending stress according to the thickness of the layer at different filling speeds (20, 50, 80mm/s) is shown in Fig. 10a and the bending stress according to the type of printing orientation is shown in Fig. 10b. These obtained results are in agreement/concordance with previous researches where the samples were tensile tested along longitudinal direction, leading to decreasing the deformability and increasing of the rigidity^{1, 4-6, 18, 24}. A SEM image structure analysis as is

Table 3 — Mechanical properties of PLA material obtained by FDM method^{18,19}.

PLA properties	Values
Tensile strength	(15.5–72.2)MPa
Flexural strength	(52–115.1) MPa
Tensile modulus	(2.020–3.550)GPa
Flexural modulus	(2.392–4.930)GPa
Elongation at break	(0.5–9.2) %

Table 4 — Process parameters and their levels²³.

Parameter	Value
Orientation type	Flat (F), On-edge (O), Upright (U)
Thickness of layer (mm)	Lt = {0.06; 0.12; 0.18; 0.24}
Filling speed (mm/s) flow (mm ³ /s)	Fr = {20(1.9), 50(4.8), 80(7.7)}

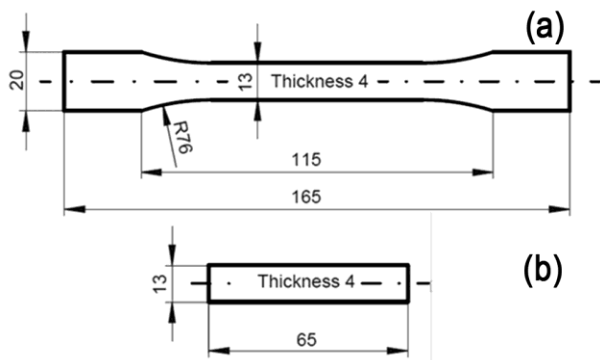

Fig. 5 — Standard samples for mechanical testing (a) Tensile and (b) Three-point bending^{21, 22}.

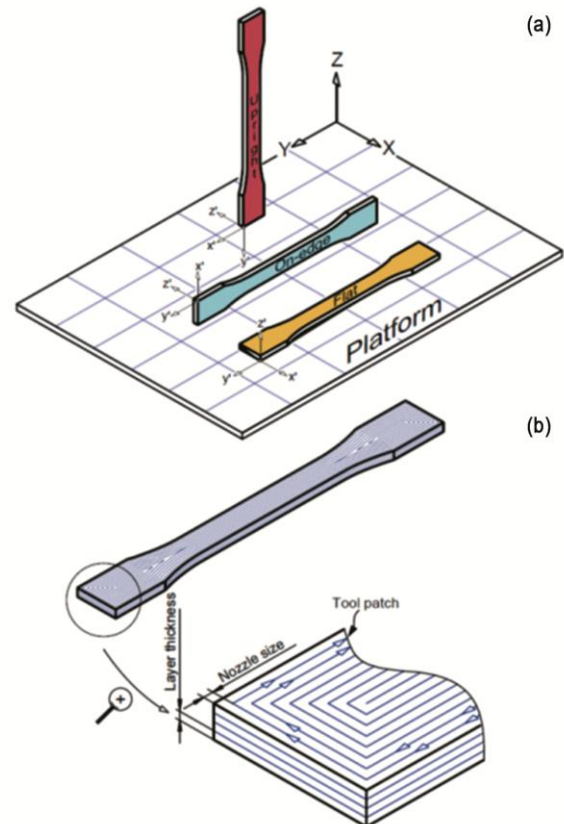

Fig. 6 — Process factors (a) Build orientation and (b) Layer thickness & deposition perimeter²³.

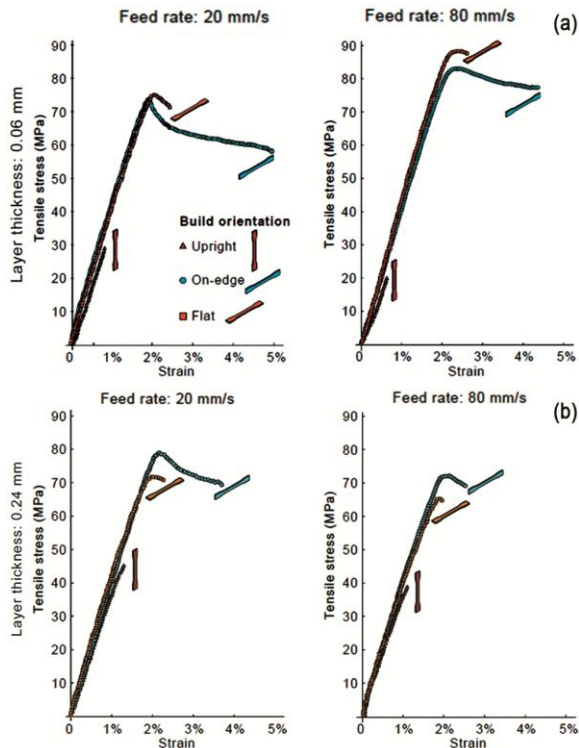

Fig. 7 —The average strain-stress curves for tensile tested samples under different printing conditions (a) 0.06 mm thickness of layer and (b) 0.24mm thickness of layer²³.

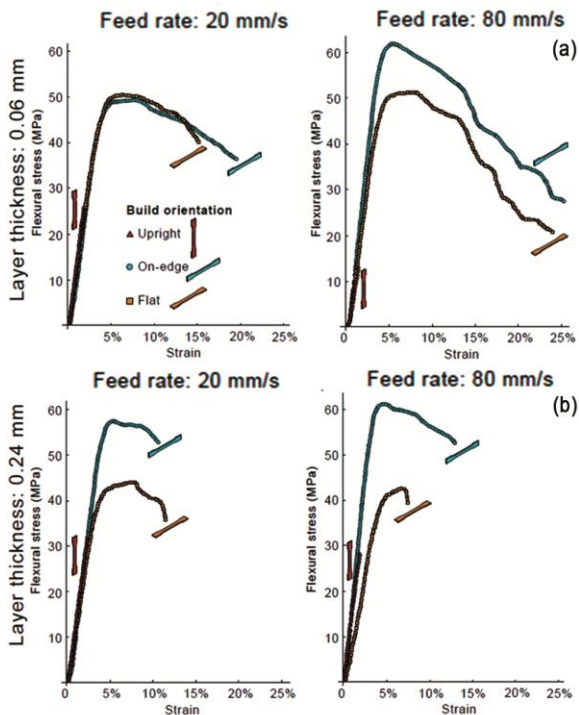

Fig. 8 — The average strain-stress curves for bending tested samples under different printing conditions (a) 0.06 mm thickness of layer and (b) 0.24mm thickness of layer²³.

shown in Fig. 11 in case of 0.06mm thickness of layer and 20mm/s feed rate for all three types of print orientation.

4.1.2 Construction orientation

The “upright” samples showed a break between layers with reduced strength and stiffness performances. On the other hand, the “on-edge” and “flat” printed samples have revealed a transverse rupture of the layers. The samples with such orientation types have the high mechanical properties. Also, the results revealed brittle behavior in case of “upright” position and ductile behavior for “on-edge” and “flat” positions.

The best flexural properties were obtained in case of “on-edge” orientation type, regarding the strength resistance and stiffness. In case of “flat” orientation type the values could be compared with the results in case of “on-edge” orientation. More, the “on-edge” samples orientation type presents the best strain-stress in terms of ductility. Can be conclude that the “on-edge” orientation type revealed the high mechanical properties in terms of stiffness, strength and ductility.

4.1.3 Thickness of layer (Lt)

This printing parameter had a different effect on the tensile strength and flexural tests, these one being in close relationship with the print orientation parameter. For the “upright” orientation type, the flexural and tensile strength increases with the layer thickness becomes higher. For variations of 0.12mm to 0.24mm thickness of layer, the in maximum flexural and tensile strengths have minor importance in case of “on-edge” and “flat” orientation types. However, for the 0.06mm layer thickness, the results are higher in terms of tensile and lower flexural strength. Also, has been concluded that once with the increasing of the thickness of the layer the ductility decreased.

In the case of samples placed “upright” vertical, the flexural and tensile strengths decreases with the feed rate increases. For the “on-edge” and “flat” orientation types, the feed rate has a minor effect for tensile and flexural strengths results, except for Fr = 80 mm/s under tensile load. Also, this process parameter showed a different behavior for Lt = 0.06 mm. In addition, as for the layer thickness effect, ductility decreased as the thickness of the layer increased.

4.2 Effect of Continuous Fibers Reinforcement on the Mechanical Properties of PLA Samples

In what concern the biggest challenges faces by researchers nowadays refers to reinforcement of

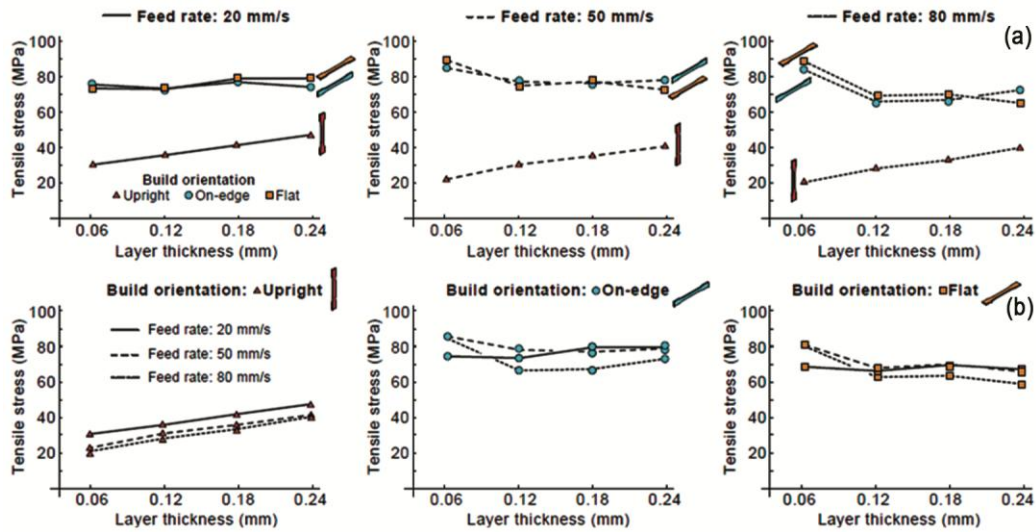

Fig. 9 — Average of tensile stress's depending on the thickness of the layer (a) For different fill speeds and (b) Depending on the type of print orientation²³.

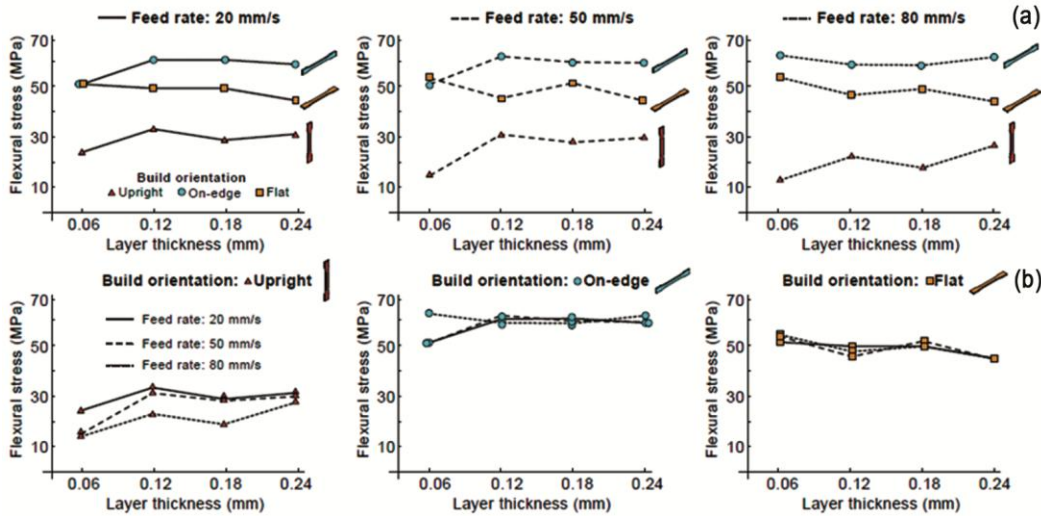

Fig. 10 — The average of flexural stress according to the thickness of the layer (a) For different feeds rate and (b) Depending on the orientation of the printing²³.

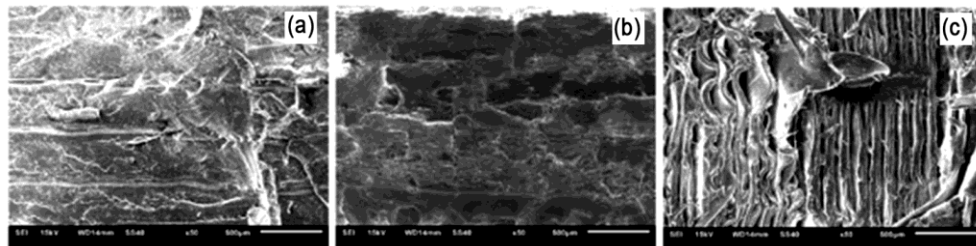

Fig. 11 — SEM images showing broken surfaces details of tensile test samples: thickness 0.06mm, feed rate 20mm/s, 50X magnification: (a) Orientation in upright position, (b) Flat orientation and (c) On-edge orientation.

polymer composites with continuous fibers means the higher mechanical properties compared with staple fibers,²⁵. An innovative technology was developed by Matsuzaki, Ueda²⁶ for impregnation of continuous filament. The filament and the resin fiber were melted separately before heating and mixed into the printing head. Afterwards, the mixture was deposited on the printing surface. The Fig. 12 presents the printing head and the integration of the continuous fibers. Also, carbon fiber and natural fiber jute have been used as reinforcements. The advantages of continuous fibers against of short fibers as reinforcement and other 3D printing methods can be seen in Fig. 13.

Namiki, Ueda²⁴ have implemented the same technique (Fig. 12) for producing parts from polylactic acid (PLA) composite reinforced with carbon fiber. The tensile strength of PLA sample reinforced with continuous carbon fiber, printed by Fused Deposition Modeling method, by Li, Li²⁷, can reach up to 91MPa, while in the case of short carbon fibers it is only 68MPa. The weak link between PLA and carbon fiber²⁸ can significantly affect the mechanical properties of this method, but surface modification of the carbon fiber beam with methylene dichloride and PLA particles²⁷ improved the adhesion and increased the resistance to tensile and bending.

Figure 14 shows the maximum tensile and bending strengths of pure PLA samples, PLA reinforced with carbon fiber and PLA reinforced with modified fibers (black dotted lines). The green circles in Fig. 14a indicate different phases of the tensile strength, such as loading of the PLA material between the fastener and the test sample at the beginning of the test and a slight decrease in the slope of the curve due to the detachment of the matrix-fiber interface. The marked circles in Fig. 14b signify the resin-to-fiber change process at the beginning of the test. The next circle in Fig. 14b shows the plastic elongation of PLA polymer

chains that continue to bear the load after breaking of the carbon fibers. Tian, Liu²⁹ performed a systemic analysis of the interface and performance of printed parts from PLA composites reinforced with continuous carbon fiber.

Figure 15 presents the microstructure and the cross-section of the tensile test sample and the continuous fibers in the broken area. Can be observed in Fig. 15a that the interface between layers it doesn't

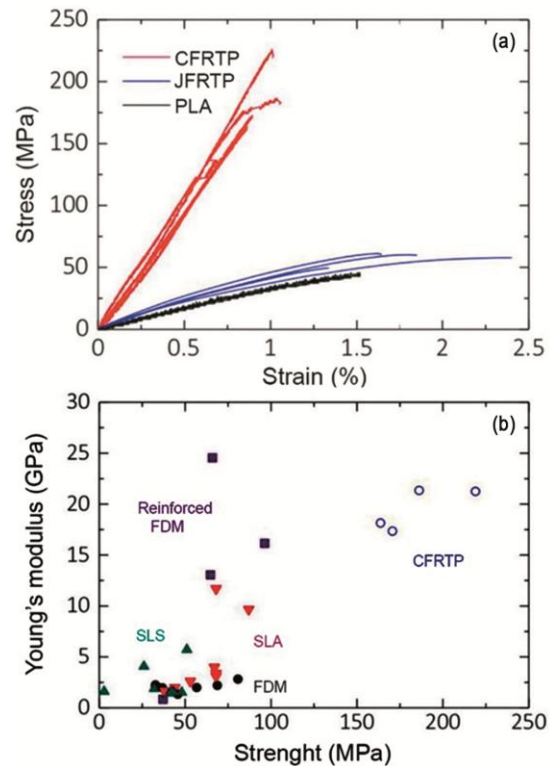

Fig. 13 — (a) PLA stress-strain curves, thermoplastic reinforced with unidirectional carbon fiber (CFRTTP) and thermoplastic reinforced with unidirectional jute fiber and (b) The Young's Module and continuous carbon composite resistance versus composites made by FDM, SLS, Commercial SLA, and FDM 3D printing²⁶.

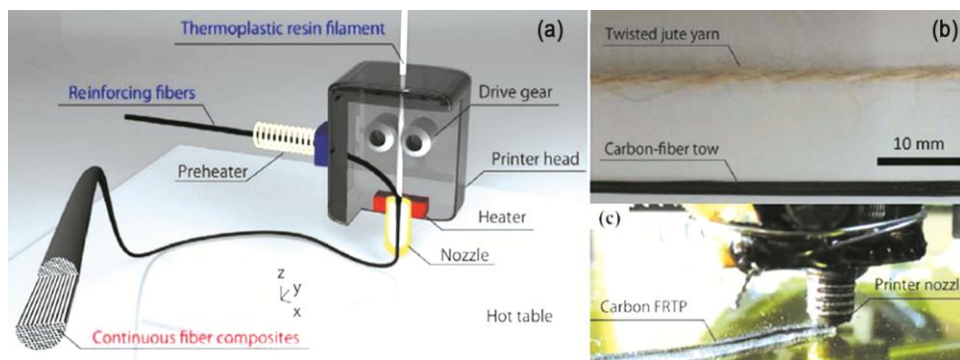

Fig. 12 — FDM of continuous fiber by nozzle impregnation (a) Scheme, (b) Continuous fibers bundles and (c) Prototyping process²⁶.

exist (without delamination), due to the PLA reinforced with continuous carbon fiber flowability, presented at high temperature, 240°C. In what regards the impregnation between matrix and fiber bundle, these one can be observed in Fig. 15c. In Fig. 15b, the carbon fiber bundle was impregnated in the PLA matrix, being achieved a good bonding between matrix and single carbon fiber. Figure 16 presents the

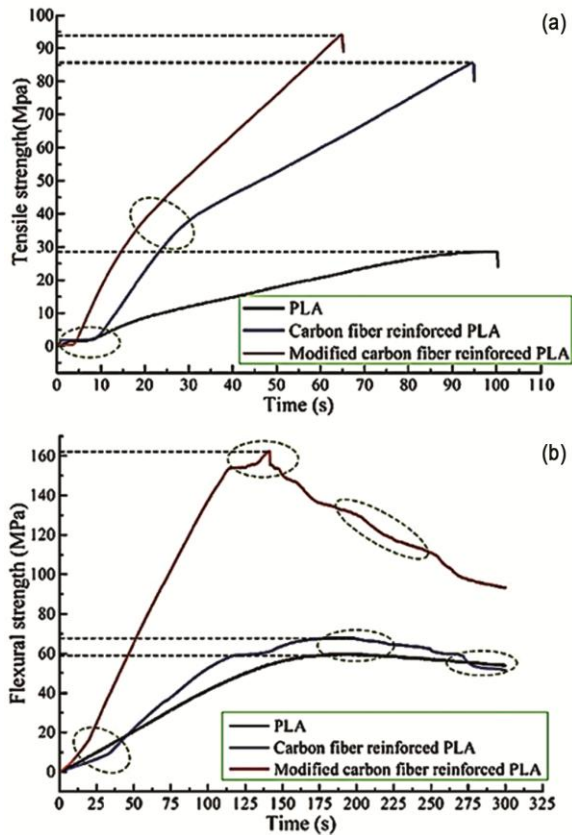

Fig. 14 — The mechanical properties of the carbon fiber modified with methylene dichloride solution compared to normal carbon fiber reinforcement and pure PLA; black dotted lines indicate maximum strength, and the green areas presents different phases of the tensile and bending tests (a) Tensile strength and (b) Bending strength²⁷.

ability of this method to obtain geometry composed from large curves without losing continuity. Markforged, the most advanced 3D printing company, revolutionized through introduction of continuous fiber (as carbon fiber, fiberglass, Kevlar *et al.*), in additive manufacturing. Markforged appears as a kind of “super 3D printer” because of the fiber capability, but Continuous Composites seems to portray the image of a “super composite system”, as they are directly addressing the needs of those building with composites³⁰.

Lewickiet *al.*³¹ was modeled the flow of an epoxy reinforced with 8% carbon fiber through the nozzle tip. In these simulations, carbon fibers have been modeled as discrete particles and have been considered fiber-fiber interactions and wall-fiber interactions. The fibers were treated as separate domains in which the fluid was modeled as an incompressible rigid body. The particle-particle interactions have been implemented with unequal contact forces, through friction. Also, these

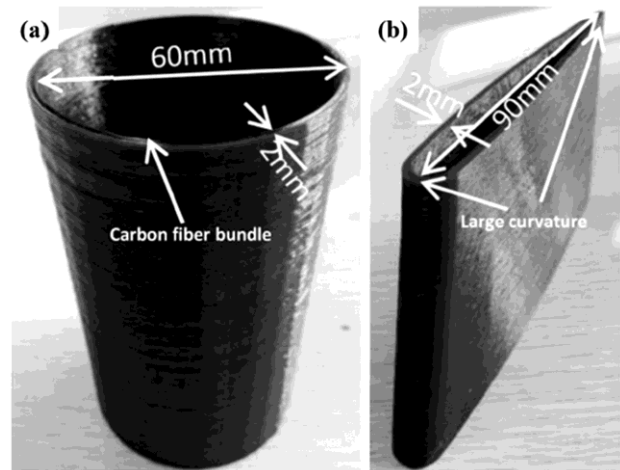

Fig. 16 — Components from PLA reinforced with continuous carbon fiber, obtained by FDM method in order to reveal the 3D printing capability of large continuous carbon fiber curves²⁹.

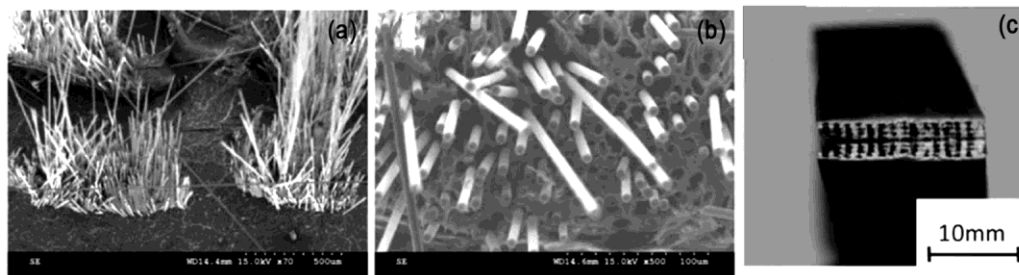

Fig. 15 — The microstructure of PLA reinforced with continuous carbon fiber having continuous carbon fibers in the rupture area (a & b) The total cross-section; and (c) Interface²⁹.

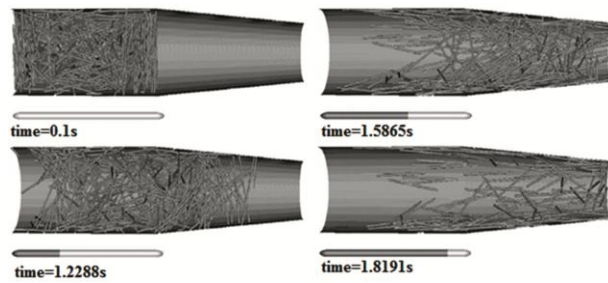

Fig. 17 — Evolution of fiber orientation versus time at constant pressure³¹.

interactions with the surrounding fluid have been described with the fluid dynamics equations. Figure 17 illustrates the evolution of the orientation type of an initially randomly oriented fiber arrangement. Starting from an assumed random orientation during the simulation, the fibers align in the flow orientation, starting from the walls where the friction forces are highest and then progressing inside according to the profile of the fluid parabolic speed^{32, 33}. Due to the high cost of calculating this simulation and small volumes limiting, a second large-scale analysis was performed using the CFD software. Nevertheless, the target has been put on the flow global dynamics with the speed ranges corresponding fields. Fiber orientations were not calculated and was assumed based on speed information³².

5 Conclusions

Taking in to account the strengths and weaknesses of the main 3D printing technologies, pointed in this paper, was decided that the most useful method in case of biodegradable material for rapid prototyping scientific research is the fused deposition modeling. Also, by considering the fact that by FDM technology, objects and functional parts can be produced using a wide variety of affordable nontoxic materials and equipment places this additive manufacturing method at the forefront of the most used 3D printing technologies. The growing concern of the researchers in what regards the negative effects of plastics on the environment and by default the effects of 3D printing parts/scrap of material have led to the development of a large number of biodegradable, recyclables, compostable materials that provide at least superior properties towards to common materials. In this respect, of following the prototyped parts competitiveness in case of biodegradable materials use, a bibliographic analysis of the literature referring to the most used biodegradable material in 3D printing, namely PLA,

was realized. The experimental results were focus on construction orientation, layer thickness and feed rate.

As a main observation, the "on-edge" orientation type could be chosen in order to get the highest mechanical properties.

If ductile behavior with optimal print time, strength and stiffness is desired the below recommendations are necessary:

- (i) higher layer thickness and lower feed rate for "upright" and "on-edge" orientation types.
- (ii) lower layer thickness and higher feed rate for "on-edge" and "flat" positions types.

In case of desired a minimum printing time a high filling speed and layer thickness are recommended.

The lack of results in the scientific research regarding potential variables studies like build material, extruder temperature, shell, *etc.*, emphasizes the need of researches in this directions in order to improve the optimal settings understanding and the behavior of 3D prototyped parts from mechanical point of view.

The reinforcement of PLA material with fibers using FDM technology improves significantly the mechanical properties of the 3D obtained parts. In what concern the reinforcement with continuous fiber of PLA material, the common reinforcement method has been improved, therefore, the additive manufacturing by material extrusion, being closer to different production industries. One of these improvements consists in the mixing of the continuous carbon fibers in the printing head of the equipment, thus improving the adhesion of PLA matrix with fibers.

The FDM technology becomes more and more adopted by research institutes, companies and consumers due to their advantages regarding costs, products quality, functionality and manufacturing time.

Acknowledgement

This work was supported by a grant of the Romanian Ministry of Research and Innovation, CCCDI – UEFISDI, project number PN-III-P1.2-PCCDI-0446/82PCCDI/2018, acronym TFI PMAIAA/FAMCRRIA, within PNCDI III.

References

- 1 Redwood B, Schoffer F & Garret B, The 3D Printing Handbook Technologies, Design and Applications (Hardcover) November 14, 2017, p. 31
- 2 <https://www.3dhubs.com/knowledge-base/additive->

- manufacturing-technologies-overview, Accessed at 12.07.2018
- 3 <http://www.ziare.com/internet-si-tehnologie/tehnologie/ce-este-cum-functioneaza-si-ce-perspective-are-printarea-3d-1397628>, Accessed at 05.08.2018
 - 4 https://store3d.ro/category/notiuni-de-baza-despre-tehnologia-de-imprimare-3d/https://en.wikipedia.org/wiki/Applications_of_3D_printing, Accessed at 05.08.2018
 - 5 Das M & Balla V K, Additive Manufacturing, Eds. Bandyopadhyay A & Bose S (CRC Press, Boca Raton), 2nd Edn, ISBN-13:978-1-138-60925-9, 2015, p. 377
 - 6 Zeltmann S E, Gupta N, Tsoutsos N G, Maniatakos M, Rajendran J & Karri R, *JOM*, 68(7) (2016)1872–1881, DOI: 10.1007/s11837-016-1937-7
 - 7 Novakova-Marcincinova L & Novak-Marcincin J, *International Journal of Industrial and Manufacturing Engineering*, 6(10) (2012) 2082-2085
 - 8 Pilla S, Handbook of Bioplastics and Biocomposites Engineering Applications (John Wiley & Sons publish, New Jersey), 2011, ISBN:9781118203699,1-14
 - 9 <http://my3dmatter.com/>, Accessed at 05.08.2018
 - 10 <https://all3dp.com/1/3d-printer-filament-types-3d-printing-3d-filament/>, Accessed at 05.08.2018
 - 11 <https://www.stratasysdirect.com/applications/production-parts>, Accessed at 05.08.2018
 - 12 Woodfield T B F, Malda J, de Wijn J, Peters F, Riesle J & van Blitterswijk C A, *Biomaterials*, 25 (2004) 4149–61
 - 13 Daljinder Singh, RupinderSingh&Kamaljit Singh Boparai, *Journal of Manufacturing Processes*, 31 (2018) 80-95
 - 14 SeyedHamidrezaGhaffar, Jorge Corker & Mizi Fan, *Automation in Construction*, 93 (2018) 1-11
 - 15 Gibson I, Kvan T & Ming L W, *Rapid Prototyp. J.*, 8(2) (2002) 91-95 (<https://doi.org/10.1108/13552540210420961>)
 - 16 Leon-Cabezas M A, Martinez-Garcia A & Varela-Gandia F J, *Procedia Manufacturing*, 13 (2017) 738-745
 - 17 P.L.A. SMARFIL, 2016 (www.smartmaterials3d.com) Accessed at 09.08.2018
 - 18 Kotlinski J, *Rapid Prototyping Journal*, 20 (2014) 499-510.
 - 19 Lanzotti A, Grasso M, Staiano G & Martorelli M, *Rapid Prototyping Journal*, 21 (2015) 604-617
 - 20 WitboxBQ, 2016, https://www.bq.com/es/witbox-_2, Accessed at 05.08.2018
 - 21 D790, ASTM Standard test method for flexural properties of unreinforced and reinforced plastics and electrical insulating materials, Annual Book of ASTM Standards 10 (2010) 1–11
 - 22 D638, ASTM Standard test method for tensile properties of plastics, Annual Book of ASTM Standards 10 (2010) 1–16
 - 23 Chacon J M, Caminero M A, Garcia-Plaza E & Nunez P J, *Materials and Design*, 124 (2017) 143-157
 - 24 Namiki M, Ueda M, Todoroki A, Hirano Y & Matsuzaki R, *Proceedings of the Society of the Advancement of Material and Process Engineering*, Seattle, 2-5 June 2014, 4328
 - 25 Parandoush P & Lin D, 182 (2017) 36-53
 - 26 Matsuzaki R, Ueda M, Namiki M, Jeong T-K, Asahara H, Horiguchi K, et al., *Sci Rep*, 6:23058 (2016) DOI: 10.1038/srep23058
 - 27 Li N, Li Y & Liu S, *J Mater Process Technol*, 238 (2016) 218–25
 - 28 Yu T, Ren J, Li S, Yuan H & Li Y, *Compos A Appl Sci Manuf*, 41 (2010) 499–505
 - 29 Tian X, Liu T, Yang C, Wang Q & Li D, *Compos A ApplSciManuf*, 88 (2016) 198–205
 - 30 <https://markforged.com>, Accessed at 18/12/2018
 - 31 Lewicki J P, Rodriguez J N, Zhu C, Worsley M A, Wu A S, Kanarska Y, Horn J D, Duoss E B, Ortega J M, Elmer W, Hensleigh R, Fellini R A & King M J, *Sci. Rep.* 7 (2017) 43401 (<http://dx.doi.org/10.1038/srep43401>)
 - 32 Brenkena B, Barocioa E, Favaloroa A, Kuncb V & Byron Pipesa R, *Additive Manufacturing*, 21 (2018) 1-16
 - 33 Nedelcu D, Stohr T, Ciofu C & Mindru D, Proceedings of the 13th International Conference on Modern Technologies, Quality and Innovation, (2009) 455-459, ISSN 2066-3919