

## Design and development of an instrument for testing electrical insulation of technical textiles

Anindita Sengupta<sup>1</sup>, Sanjoy Debnath<sup>2</sup> & Surajit Sengupta<sup>2,a</sup>

<sup>1</sup>Indian Institute of Engineering Science and Technology, Howrah 711 103, India

<sup>2</sup>ICAR -National Institute of Research on Jute and Allied Fibre Technology, Kolkata 700 040, India

Received 27 July 2016; revised received and accepted 24 March 2017

An attempt has been made to develop an instrument to measure the electrical insulation of technical textiles. Developed digital instrument measures resistance in terms of Mohm/Gohm in the transverse direction of textile material up to 2 cm thickness with 99.6% accuracy. The same sample has been tested 30 times and the deviation between minimum and maximum values is found insignificant at 1% confidence level. This instrument is user friendly, low cost, precise and easy to calibrate. Some tests using developed instrument show that the electrical resistance of fabric decreases with the increase in temperature, moisture content and area density of fabric. The electrical resistances, however, increases with thickness of fabric. The instrument is useful to understand the suitability of fabric for electrical insulating products like gloves, jackets, floor-covering, etc.

**Keywords:** Canvas fabric, Cotton, Electrical insulation, Hessian fabric, Jute, Needle punched fabric, Nonwoven, Polyester, Polypropylene, Woven fabric

### 1 Introduction

Textile materials are used as insulator since the inception of electrical engineering<sup>1</sup>. About two hundred years back, Michael Faraday wound up coils of wire which he insulated with twine and calico because cotton products are readily available, strong, flexible and most adaptable to various shapes and forms. Since then, a lot of investigations have been carried out to understand the electrical insulating property of different natural fibres. The first material to insulate the conducting thread was silk<sup>1</sup> used by Stephen Grey in 1729. From 1910 to 1955, several workers<sup>2-10</sup> have done commendable work on different textile fibres. After 1955, very few works have been carried out adopting various methods and devices to measure resistance. But, those were not converted to commercial instrument. Berber<sup>11</sup> has proposed a method for measuring the electrical resistivity of textile materials considering their compressional properties.

Now-a-days, the use of textile material for this purpose is very less. This is mainly due to the development of low cost synthetic polymers with excellent insulation property. Hence, there is almost

no research on electrical insulation of textiles from natural fibre for last few decades after advent of synthetic materials. On the contrary, researchers<sup>12-18</sup> are now interested to use synthetic fibres and change the inherent electrical insulation property of textiles artificially to make it effective flexible conductor and electro-magnetic shielding material. Some electro-physical properties of textile samples having different forms and raw material compositions were studied by Asanovic *et al.*<sup>19</sup>. They developed a device for measuring electrical resistance. Special capacitance cell was used for measuring dielectric properties of woven fabric. Hains *et al.*<sup>20</sup> studied electrostatic properties of polyurethane coated textiles used for protective clothing. Gonzalez *et al.*<sup>21</sup> proposed a mathematical modelling of electrostatic propensity of protective clothing systems. The research and development in the field of electro-textiles have been reported by a number of scientists<sup>22-25</sup>, such as electrical resistance of jute based needle-punched nonwoven.

At present, the environment conscious persons are trying to eliminate synthetics and again concentrating on biodegradable natural products. There is enough potential of using natural textile materials as insulator. It is better to use textile material where heat is generated in the conductor, as it can melt the polymer

<sup>a</sup>Corresponding author.  
E-mail: drssengupta42@gmail.com

insulator, especially in high voltage appliances like electric iron, heater, etc. Proper design and material can facilitate use of textiles as electrically insulating gloves, jackets (apron), shoes, etc. Specially designed textile fabric can also be used as floor covering in the room where high voltage electrical appliances are kept. The electrical insulation of a textile material can also indicate moisture condition and amount of static electricity generated during processing.

In electrical engineering, generally electrical resistance or conductance of any substance is measured by multi-meter or megger. But that is not suitable for measuring textile material because of its range of measurement and holders. There is a British standard BS EN 1149 for measuring electrical surface resistivity. The universal (suitable for all types of materials) instrument following this standard is not available.

In this study, an attempt has been made to develop an instrument to measure the transverse electrical insulation of fabrics, based on the principle that the electrical insulation of an object is a measure of its resistance against the movement of a steady electrical current. Some woven and nonwoven samples have been tested to understand their insulating property to ascertain the performance of instrument. In the present context, the equipment has been used in the field of technical textiles, especially in protective textiles and electro-textiles. The uniqueness of this study is to develop a system with proper fabric holding jaws and required electrical insulation range to measure all possible types of textile fabrics with

highest accuracy. The measurement of electrical resistance of different fibres/fabrics may open new avenues for use of such fibres. This attempt is intended to provide a general idea on to what extent the textile products can be used as electrical insulating material and other features affecting the successful use of the textile products for insulating gloves, jackets, floor-covering, etc.

**2 Materials and Methods**

**2.1 Principle of Operation**

A circuit for measuring current-voltage characteristics of textile material has been set up, as shown in Fig. 1. It consists of step down transformer in a 230 V 50Hz line to reduce the voltage to 12 V followed by rectifier to make AC to DC. This 12 V DC is fed to control unit. In the parallel connection the 12 V DC is fed to an oscillator to make the DC to AC followed by a step up transformer to increase the voltage to 1000V AC which is again converted to 1000V DC by a rectifier. This voltage is applied to the fabric, kept with suitable fabric holder.

Figure 2 shows the line diagram of different subsections of the insulation tester. From the diagram, it is revealed that there are two limit switches (SW1 and SW2). Left limit switch is SW1 and right one is SW2 along with one test switch (SW). If SW1 is closed, the NO terminal is connected to +12V terminal. 12 V DC is used as the input to DC/AC converter. When the timer INIT terminal is ON, SW2 is closed and if test switch SW is made ON, it makes other NO terminal connected to the supply. This

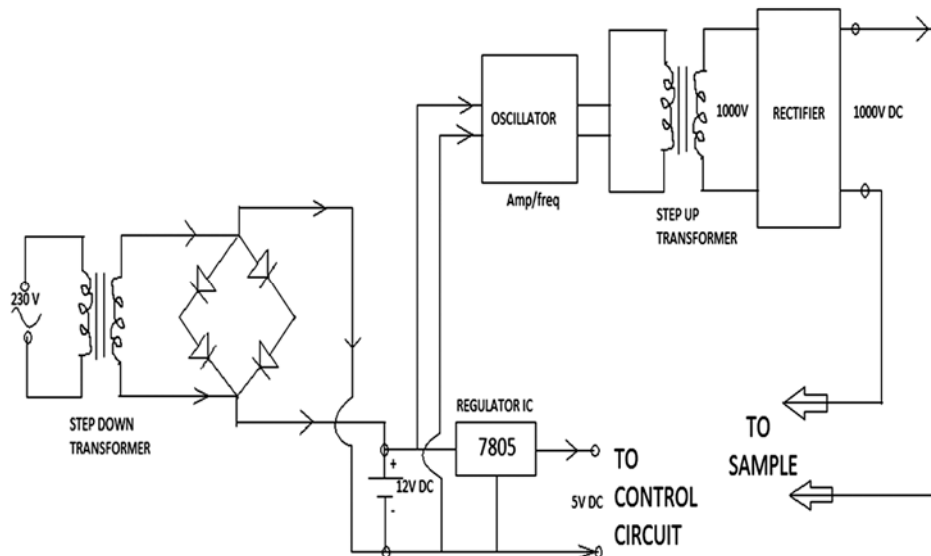

Fig. 1 — Circuit diagram of insulation tester for fabric

makes positive terminal of 12V connected to the 12V of Relay board; negative terminal has already connected, so relay coils are being energised. Two pairs of NO/NC terminals are energised activating the HOLD as well as TEST subsections of Measurement & Display board. This initiates the insulation resistance measurement.

The procedure for resistance measurement is simply an ohmic measurement set up. High voltage (1000V) supply is fed to the sample with a series resistance and current measuring facility. It is a standard measurement arrangement [Fig. 3(a)] which takes supply voltage and series current as input and calculates the resistance in Mohm.

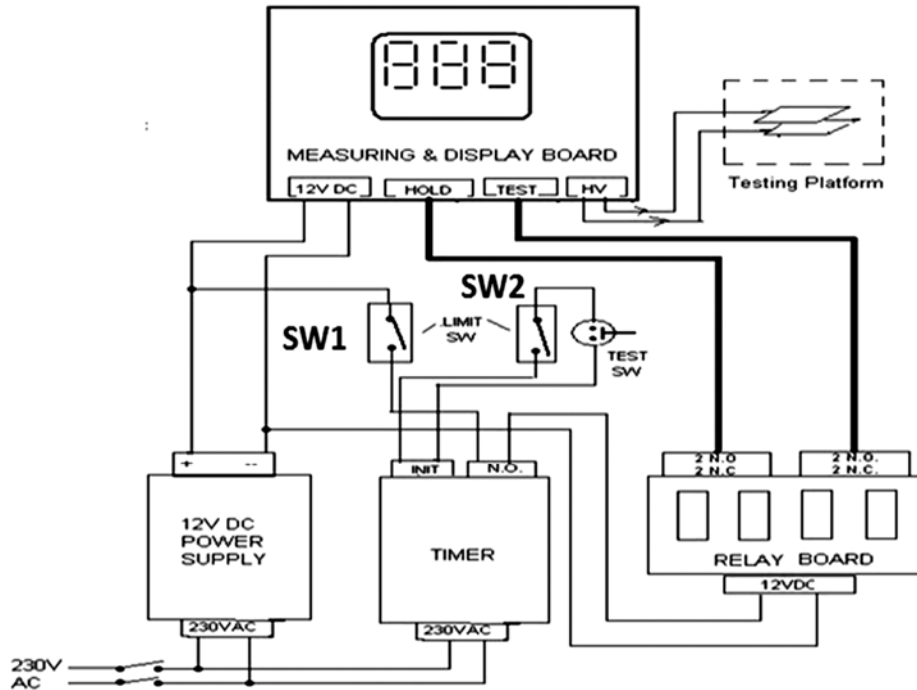

Fig. 2 — Block diagram of electrical insulation tester

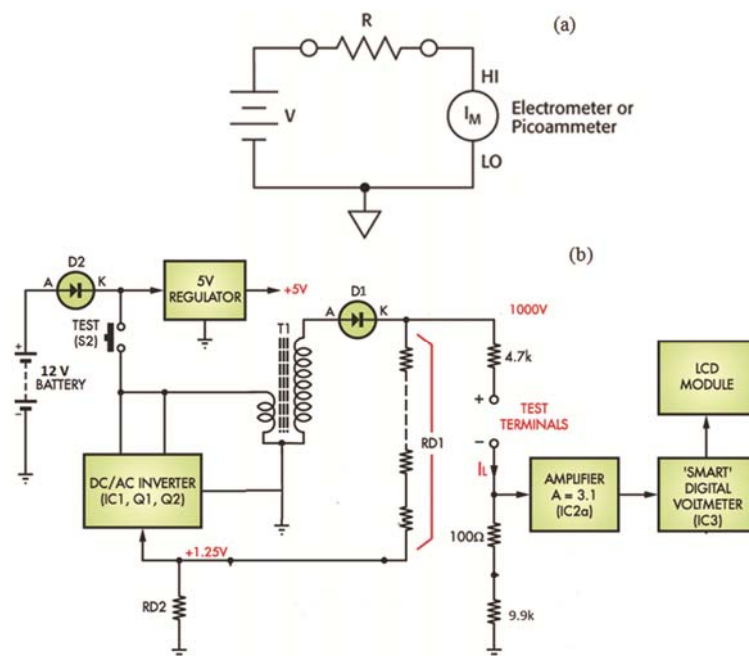

Fig. 3 — (a) Simplified circuit of resistance measurement and (b) detailed circuit for resistance measurement

The 12V DC is required for the input to DC/AC inverter and it is in action only when test button is pressed. The generated low signal is then stepped up to 1000V by a step up auto transformer shown in Fig. 3(b). The resulting high voltage AC is then rectified using ultra-fast diode D1 to produce the test voltage of 1000V.

The metering section is used to measure leakage current ( $I_L$ ), if any [Fig. 3(b)] flowing between the test terminals and consequently it calculates the external resistance connected between them, as the generated DC test voltage is already known.

Resistance RD1 and RD2 are used to provide negative feedback to control the converter's operation and to maintain the output voltage at correct level. It feeds a small proportion of the high voltage DC output back to one input of a comparator inside IC1, where it is compared with an internal 1.25V reference voltage.

As soon as the test button is released, the converter stops and the high voltage leaks away via RD1 and RD2. This provides both the safety feature and a simple way to achieve maximum battery life. The

metering section uses a shunt resistor connected between the negative test terminal and ground to sense any leakage current ( $I_L$ ), which may flow between the test terminals. It is the voltage across this resistor, which is measured to determine the leakage current.

**2.2 Description**

**2.2.1 Display**

An LCD display is used for showing the result and it shows the electrical resistance of the fabric in Mohm due to current passing through the fabric.

**2.2.2 Control**

Control switches are there for power off-on and test off-on [Fig. 4(a)]. The test will start when test 'off-on' switch is in the 'on' condition. After 30s the value stabilises and the instrument stops testing. The control panel is perforated for heat dissipation. Time of test can be set by clockwise or anti-clockwise rotation of a screw placed at the side of the tester.

**2.2.3 Calibration**

Calibration has been done by using a  $2.54 \times 2.54$  cm<sup>2</sup> block having known resistance (50 Mohm)

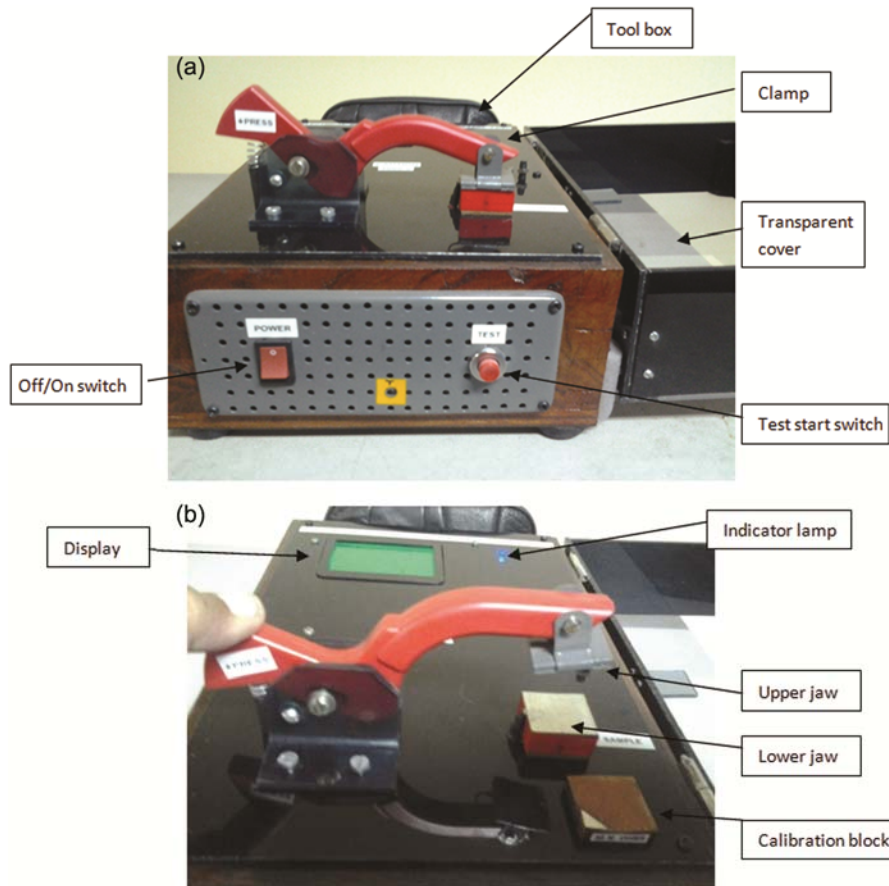

Fig. 4 — Description of Instrument (a) front view and (b) clamping of sample

which will be supplied with the instrument. [Fig. 4(b)]. If the block is kept in place of fabric between the jaws, the resistance should be 50 Mohm. At present, no calibration facility is exposed for the user. The resistance connected in series is a potentiometer mounted on the PCB and only be accessed by the manufacturer in the laboratory. As the measurement is with high DC voltage, series component cannot be exposed to the user for safety purpose. But it is found that if calibration is getting disturbed, series resistance should be varied with proper care to regain calibration. The screw (given outside) is for timer setting of resistance measurement.

#### 2.2.4 Fabric Clamping Jaws

Fabric sample is placed between two square blocks of  $2.54 \text{ cm}^2$  which can be denoted as upper and lower jaws. 1000 V DC is applied between the jaws. A spring loaded clamp holds the jaws in pressed condition on the fabric [Fig. 4(b)].

#### 2.2.5 Safety Device

There is a transparent top cover which protects the operator from the accident because the instrument works with high voltage (1000V). This caution has been mentioned near the sample mounting. Test can only be performed after closing the top cover. When the cover is closed, the strips St1 and St2 close limit switches S1 and S2 (Fig. 5), which in effect closes SW1 and SW2, as shown in Fig. 2. When the cover is open, circuit is also open but 12V does not reach the relay board and hence circuit does not work.

#### 2.2.6 Tools

A tool box is attached at the back of the instrument which contains a sample template, a standard resistance of 50 Mohm for calibration, a scissor, a marker, etc.

#### 2.3 Features/ Specifications of Instrument

The instrument comprises electrical control operations and settings, digital display of resistance value in Mohm, calibration by standard block, manual sample mounting, suitability for wide range of fabrics (especially for technical textiles, semi-rigid fabric, nonwoven, canvas etc), size  $35 \times 16 \times 18 \text{ cm}^3$ , weight 3 kg, sample size  $2.54 \times 2.54 \text{ cm}^2$ , gauge length 0.01 – 2 cm, test range 10 Mohm to 200 Gohm, and accuracy 99.6%.

#### 2.4 Repeatability

A  $500 \text{ g/m}^2$  jute nonwoven block of  $2.54 \times 2.54 \text{ cm}^2$  was tested 30 times and the minimum and maximum data of those 30 test were identified. It is found that the deviation between minimum and maximum data is statistically insignificant at 1% level as  $t$ -value is found 1.52 which is less than  $t_\alpha - 2.58$  at 1% probability level<sup>26</sup>. Hence, it can be concluded that the test results of the developed instrument are repetitive.

#### 2.5 Accuracy

The calibration block, with pre-engineered resistance value, has been tested thirty times without adjustment. The deviation in maximum (50.2 Mohm) and minimum (49.9 Mohm) values from the mean (50.1 Mohm) has been calculated and it is found that the maximum deviation is obtained between mean and the minimum value of resistance is (0.399%). Therefore, the reliability of result is not less than 99.6%. For better reliability on accuracy, three calibration blocks having different resistance values may be used to cover a wide range of resistance.

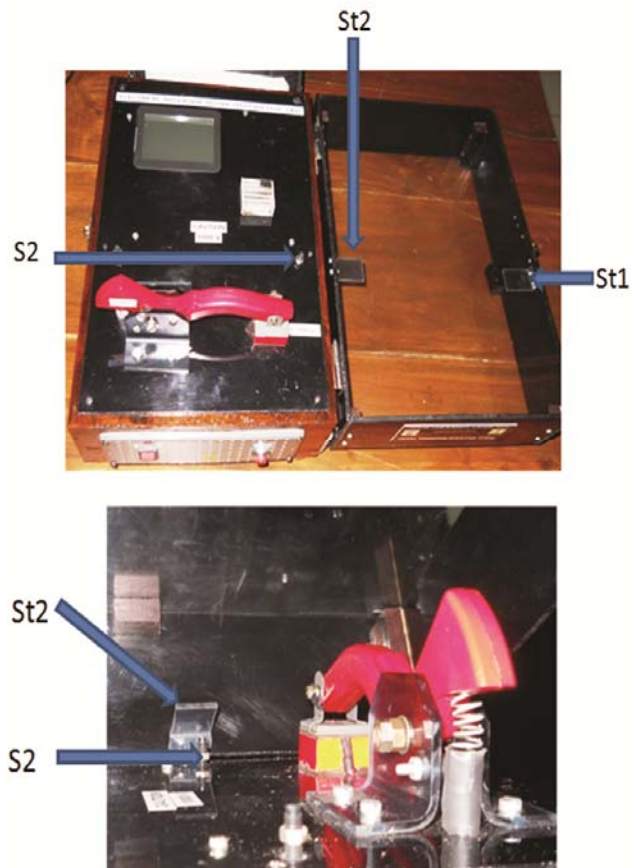

Fig. 5 — Safety mechanism

**2.6 Testing Method**

**2.6.1 Sample Length and Gauge Length**

The effective sample size is  $2.54 \times 2.54 \text{ cm}^2$ . As it is non-destructive test, different positions of a big fabric can also be tested without destroying it. Hence, either cut the sample bigger than  $2.54 \times 2.54 \text{ cm}^2$  from different parts of a fabric randomly (30 numbers) using cutting template or use different parts of the whole fabric randomly, as per the convenience.

**2.6.2 Testing Procedure**

Following steps were followed for testing:

(i) Condition the sample at  $27 \pm 1^\circ\text{C}$  and  $65 \pm 2\%$  RH for 24 h. Tests should be done under the same atmospheric condition.

(ii) Check the calibration – Put the instrument in 'ON' condition. Green indicator will lit up. Put the calibration block between two jaws and close the top cover. Press the 'test start' switch for once. After 30s, the value of resistance of the calibration block is fixed and is shown on display screen as 50 Mohm. If it deviates from 50 Mohm, the error per cent is to be calculated to get the real value of fabric resistance.

(iii) Clamp the fabric between the jaws

(iv) Cover the testing area

(vi) Take the reading when the display shows steady reading after 30 s. The test stops automatically.

(vii) Take another sample and perform the same steps.

(viii) Take the average of at least 30 data from different positions of the fabric.

(ix) Mean, standard deviation, coefficient of variation are calculated.

Finally, the specific resistance has been calculated by multiplying the measured mean resistance with thickness.

**2.7 Types of Fabric Tested**

Two types of jute fabrics (woven and needle-punched nonwoven) were used to measure the electrical resistance in transverse direction (along the thickness) of the fabric .

Woven jute fabrics were obtained commercially and used for the study. Two types of fabrics (i) hessian, which is openly interlaced having low area density and basically used as packaging, and (ii) canvas, which is densely interlaced having high area density were used. Cotton and cotton-polyester woven fabrics are broken twill commercial cloth. Jute, polypropylene (PP) and polyester (PET) needle-punched nonwoven fabric of  $500 \text{ g/m}^2$  were prepared in the laboratory using Dilo needle loom with 230 punches/cm<sup>2</sup> and 13 mm depth of needle penetration. Layered fabric, made up of needle-punched fabric having jute hessian in bottom, jute fibres in middle and polypropylene fibre layer in top, was used as floor covering. Basically this is felt of fibre layers entangled by mechanical means. The resistance has been converted to specific resistance multiplying by thickness. The construction parameters of all the fabrics are shown in Table 1.

**3 Results and Discussion**

**3.1 Effect of Type of Fabric**

Table 2 shows the specific resistance (SR) of different fabrics tested by the newly developed instrument. In case of woven fabric, hessian shows the highest and cotton shows the lowest specific

Table 1 — Construction of fabrics

Fabric	Area density g/m <sup>2</sup>	Thickness mm	Ends/ inch	Picks/ inch
Hessian (woven)	244	2.59	16	8
Canvas (woven)	510	3.17	30	16
Cotton ( woven)	164	1.06	20	18
Cotton -polyester (woven)	157	1.14	20	18
Jute (nonwoven)	512	4.15	-	-
Polypropylene (nonwoven)	498	5.35	-	-
Polyester (nonwoven)	502	5.04	-	-
Jute-polypropylene (80:20) (layered nonwoven)	507	5.08	-	-

(v) Press the test button.

Table 2 — Specific resistance of different fabrics

Parameter	Specific resistance, Mohm-cm							
	Woven				Nonwoven			
	Canvas	Hessian	Cotton	Cot- PET	Jute	PP	PET	Layered
Single	352	525	92	147	309	591	658	506
2-ply	529	734	131	164	672	752	736	649
3-ply	792	1416	159	191	957	833	1020	992

Cot – Cotton, PP – Polypropylene, and PET –Polyester.

resistance (SR). For nonwoven, polyester gives the highest SR probably due to its low moisture content. Therefore, to get better insulation, hessian may be used most effectively among different woven fabrics studied. Synthetic nonwoven is better insulator. Moisture regain of PP is 0.05%, whereas that of PET is 0.4%. Such a little amount of moisture is responsible for high electrical resistance in addition to higher bulk.

### 3.2 Effect of Folded Fabric

Table 2 shows resistance against different thicknesses (1, 2 & 3 folds of same fabric). It shows that specific resistance increases with the increase in number of fold. This trend is true for all types of fabric tested. From this, it can be concluded that

Table 3 — Effect of moisture content on resistance

Moisture content, %	Specific resistance, Mohm-cm				
	Canvas	Hessian	Cotton	Cot-PET	Jute nonwoven
9.03	1215	963	914	817	717
9.17	946	980	686	592	559
10.31	674	655	548	472	484
10.60	480	581	393	417	402
11.12	216	393	173	203	336
13.00	85	136	79	114	188

Table 4 — Effect of area density of nonwoven fabrics

Area density g/m <sup>2</sup>	Specific resistance, Mohm-cm			
	Jute nonwoven	PP	PET	Layered
300	821	758	731	642
450	608	681	637	610
600	459	884	591	539
750	366	924	719	628
900	356	1023	852	685

insulating property of fabric increases with the increase in ply.

### 3.3 Effect of Moisture

Canvas and jute nonwoven fabrics are conditioned at 40°C with varying relative humidity using auto humidifier and are tested in the instrument. The increase in moisture content increases the current flow, resulting in decrease in resistance (Table 3). Therefore, fabric should be moisture resistant to make it suitable as an insulator and the product should be either polycoated or made with chemically treated fibres so that jute cannot absorb moisture.

### 3.4 Effect of Area Density

As area density of needle-punched jute nonwoven increases, the specific resistance decreases (Table 4). But for other fabrics, SR initially decreases, and then increases. The decrease of resistance in higher areal density is due to increase in bulk density of fabric or decrease of void spaces. In case of PP and PET, high elongation during needling and recovery during relaxation increases the voids, resulting in increase in specific resistance. Hence, to get required insulation by fabric, the area density or bulk density is an important parameter.

### 3.5 Effect of Heating

Samples are kept in the humidifier chamber with 65% relative humidity and at varying temperature. Table 5 shows that as temperature increases, the resistance decreases. After 60°C, resistance comes to equilibrium. Temperature may rise during application of jute fabric in the electrical system. So, the effect of temperature is to be kept in mind so far as insulation is concerned.

Table 5 — Effect of heating of fabric on resistance

Temperature, °C	Specific resistance, Mohm-cm							
	Canvas	Hessian	Cotton	Cot- PET	Jute nonwoven	PP	PET	Layered
30	844	763	182	197	687	824	957	910
35	712	-	-	-	630	-	-	-
40	646	651	164	152	608	739	837	829
45	605	-	-	-	579	-	-	-
50	526	563	109	137	566	712	810	635
55	522	-	-	-	547	-	-	-
60	528	509	83	106	542	589	742	459
65	525	-	-	-	530	-	-	-



#### 4 Conclusion

Developed digital instrument measures resistance in terms of Mohm/Gohm in the transverse direction of textile material up to 2 cm thickness with an accuracy of 99.6%. The deviation of results is found insignificant at 1% confidence level. This instrument is user friendly, cost effective, precise and easy to calibrate. A safety measure is also incorporated in the instrument as it works in a high voltage and does not work in the open condition. It is useful to understand the suitability of fabric for preparing electrical insulating products like gloves, jackets, floor covering, etc. The developed instrument also shows that electrical resistance of fabric decreases with the increase in temperature, moisture content and area density of fabric. It increases with thickness of fabric. It is highest in hessian and lowest in nonwoven, keeping canvas in between. It is also essential for research and development of technical textiles when it will be used as electrical insulator.

#### Acknowledgement

Authors are grateful to Mr Sekhar Samanta, Howrah for fabrication and help rendered to develop this product. Authors sincerely acknowledge the technical help of Mr Raktim Maity, Tech. Asstt., Electrical Engineering Department, IEST, Shibpur, during the study.

#### References

- 1 Priestley J, *A Familiar Introduction to the Study of Electricity*, 2<sup>nd</sup> edn (Johnson and Payne, London), 1777.
- 2 Evershed S, *J Inst Elect Eng*, 52 (1913) 51.
- 3 Kujirai T & Akahira T, *Sci Paper Inst Phys Chem Res*, 1 (1923) 95.
- 4 Murphy E J & Walker A C, *J Phys Chem*, 32 (12) (1928) 1761.
- 5 Martin R I, *J Text Inst*, 22 (11) (1931) 165.
- 6 Marsh M C & Earp K, *Trans Faraday Soc*, 29 (1933) 173.
- 7 Baxter S, *Trans Faraday Soc*, 39 (1943) 207.
- 8 Hearle J W S & Jones E H J, *J Text Inst*, 40 (1949) T311.
- 9 Hearle J W S, *J Text Inst*, 43 (4) (1952) 194.
- 10 Hearle J W S, *J Text Inst*, 44 (1953) T117, T144, T155.
- 11 Berberri P, *Bul Shkencave Nat*, 1 (1982) 41.
- 12 Cottet D, Grzyb J, Kirstein T & Troster G, *Adv Packaging, IEEE Ttransac*, 26 (2) (2003) 182.
- 13 Salonen P, Rahmat-Samii Y, Schaffrath M & Kivikoski M, *Antennas and Propagation Society International Symposium*, Vol 1 (IEEE, Monterey, California, USA), 2004, 459.
- 14 Feller J F & Grohens Y, *Sensors Actuators B: Chemical*, 97 (2-3) (2004) 231.
- 15 Varesano A & Tonin C, *Text Res J*, 78 (12) (2008) 1110.
- 16 Han G E, Kim E A & Oh K W, *Synthetic Metals*, 123 (3) (2001) 469.
- 17 Chen H C, Lee K C, Lin J H & Koch M, *J Materials Processing Technol*, 192 (2007) 549.
- 18 Aniolczyk H, Koprowska J, Mamrot P & Lichawska J, *Fibres Text East Eur*, 12 (4) (2004) 47.
- 19 Asanovic K A, Mihajlidi T A, Milosavljevic S V, Cerovic D D & Dojcilovic J R, *J Electrostatics*, 65 (3) (2007) 162.
- 20 Hains N, Fris V & Gordos D, *Int J Clothing Sci Technol*, 15 (3/4) (2003) 250.
- 21 Gonzalez J A, Rizvi S A & Crown E M, *Mathematical modelling of electrostatic propensity of protective clothing systems*, paper presented at the Electrical Overstress/ Electrostatic Discharge Symposium, 23-25 September, 1997, 153.
- 22 Dhawan A, Ghosh T K, Seyam A M & Muth J F, *Text Res J*, 74 (11) (2004) 955.
- 23 Ghosh T K & Dhawan A, *Indian J Fibre Text Res*, 31 (1) (2006) 170.
- 24 Sengupta S & Sengupta A, *Indian J Fibre Text Res*, 37 (1) (2012) 55.
- 25 Sengupta S & Sengupta A, *J Text Inst*, 104 (2) (2013) 132.
- 26 Chambers E G, *Statistical Calculation for Beginners* (The University Press, Cambridge), 1958.