

Simple method for measurement of feltability of rabbit hair

J¹ Voráč^a, V² Štork, P¹ Saul & T¹ Gancarčík

¹ Department of Physical Electronics, Faculty of Science,
Masaryk University,

Kotlářská 2, Brno 611 37, Czech Republic,

² Textile Testing Institute, Václavská 6, Brno 658 41,
Czech Republic

Received 11 April 2014; revised received and accepted 21 July 2014

In this work, a simple method for testing the felting propensity of carded top prepared from chemically treated, short and thick animal hairs, together with the necessary devices has been developed. Similar to the Aachen felting test, external force is applied to the wet sample of the fibres until felting occurs. The felting propensity is then determined from the dimensions of the resulting felted body. The main difference is that the sample is prevented from disintegration during the procedure that usually occurs, when a standard Aachen test is applied.

Keywords: Felting test, Hat production, Rabbit hair, Wool

The felt making from animal hairs has a long tradition. Whereas the felt made up of long thin fibres (wool) has countless applications, the felt made of short hairs of rabbits, hares, and beavers has been traditionally used mainly for hat production. The mechanism of felting is complicated and not yet fully understood. A considerable amount of articles on the properties of wool fibres that are believed to influence the process of felting has been published. The directional frictional effect (DFE) caused by the scales of animal fibres is believed to be the key property that allows the felting to happen^{1,2}. Many testing methods to quantify the DFE have been proposed and successfully applied³⁻⁵. However, the DFE is not the only property that determines the felting propensity of fibres. Other properties, such as fibre length, scale frequency, scale height, and fibre diameter also play an important role in determining the extent of fibre felting⁶.

To have a more direct test of the felting properties of the fibres, a simple procedure was introduced at the German Wool Research Institute. The procedure

is nowadays known as Aachen felting test⁷. A small sample of loose wool is put into a solution and rocked on a mechanical shaker providing a three-dimensional motion for a definite period of time. The loose wool is transformed into a felt ball and the diameter of this is measured. The smaller the ball, the better is the felting propensity of the material.

All the felting tests generally used for characterising wool have been found unsuitable for rabbit hairs, mainly because of the much higher thickness-to-length ratio of the rabbit hairs compared to wool. The DFE measurements usually require binding of the fibres to the apparatus. The Aachen felting test was not reproducible for our conditions, mainly because more than one felt ball was usually formed.

Therefore, in this study a new testing procedure and apparatus has been developed for testing the felting properties of short and relatively thick rabbit fibres.

Experimental

Device Description

The testing apparatus is shown in Fig. 1. It consists of a tube with square cross-section (34 mm × 34 mm) that is open on both ends (1), a small reservoir (2), for solution of wetting agent, that is put under the tube (1) and a piston (3) with grooves along the edge to prevent suction. The piston is worked by a pneumatic cylinder (piston diameter 32 mm). The whole apparatus is a table-top device.

The device for measuring the dimensions of the felt objects is shown in Fig. 2. It is based on a standard calliper. The height is measured after applying a load of 40 g, which helps to clearly define the edge of the sample and enhances the reproducibility of the measurement. Applying excessive pressure to the measured sample while setting the position of the Vernier scale is prevented by using a simple electrical circuit and a light-emitting diode to signalise the contact of the movable scale and the applied load.

Testing Procedure

In this section, the testing procedure will be described. The principle is similar to other felting tests. A sample of rabbit top is inserted into the tube of the testing apparatus and water solution

^aCorresponding author.
E-mail: vorac@mail.muni.cz

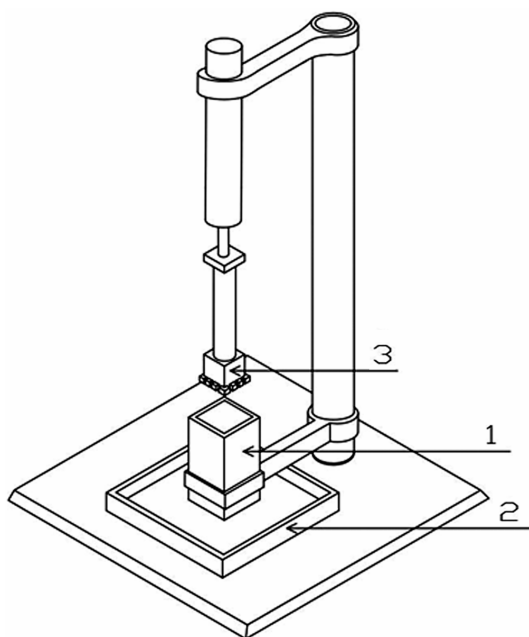

Fig. 1—Apparatus for pressing the tested sample of rabbit fibres [1 – tube with square cross section, 2 – reservoir for water solution of wetting agent and 3 – piston for pressing the sample with grooves along the edge]

of a wetting agent is poured over it. Then, external force is applied repetitively until felting occurs. The dimensions of the felted objects are measured and compared. Smaller dimensions indicate higher felting propensity.

Preparing Top Sample

Unlike wool, the rabbit hairs must be treated chemically prior to the use in production. Otherwise, the felting might not occur at all. This test is intended for chemically treated, loose, carded hairs and shall not work otherwise. In this work, 6.0 g hair was used. Because of the general lower felting propensity of the material, it is necessary to prepare the sample carefully. An important condition for the reproducibility is that there should be as few top-to-air interfaces as possible in the sample. Simply taking the top and folding it until it fits into the tube is not advisable. It is therefore suggested to homogenise the sample first by a stream of compressed air. After homogenisation, the sample is often electrically charged due to the friction during the process. The surface charge can be removed by gently pressing the fibres together with an earthed conductor.

Mechanical Treatment

The prepared top can be inserted into the tube (1) of the felting apparatus (Fig. 1). To enhance the

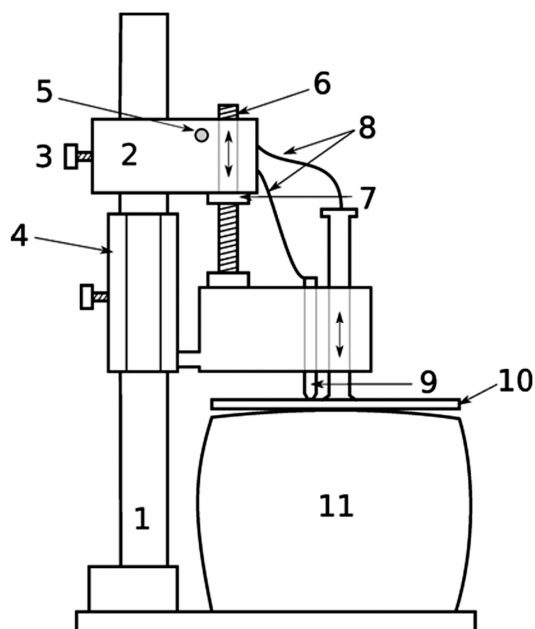

Fig. 2—Measurement of height of the sample [1 – support with scale, 2 – slider for coarse vertical adjustment, 3 – fixing screw, 4 – Vernier scale for finer height measurement, 5 – LED signalling the contact, 6 – threaded support allowing fine vertical adjustment, 7 – nut for vertical adjustment between 2 and 4, 8 – electric cables, 9 – conducting tip to signalise contact of 9 and 10 by closing a circuit and turning on the LED 5, fixed with respect to 4, 10 – defined load of 40.0 g which moves freely with respect to 4 and 9, and 11 – measured sample]

felting propensity of the sample, 75 mL of wetting agent solution in deionised water was poured into the tube. In this work, ALTARAN S8 was used in concentration of 0.5 g/L. ALTARAN S8 is a solution of sodium di-(2-ethylhexyl) sulphosuccinate in water. Technical data sheet can be found under the separate link⁸. The pH of the solution was maintained at neutral value.

After wetting, the sample was mechanically treated. The piston was operated by compressed air at the pressure of 4.0 bar, with the repetition rate of 80 beats per minute for 5 min. After that, the sample was extracted, rotated by 90° around one of the horizontal axes and treated for 5 more minutes in the new direction.

During the treatment, water solution is repeatedly pressed out of the sample into the reservoir (2) and soaked back into the sample when the piston rises. The piston must have a grooved edge, otherwise the sample may be damaged by the strong suction when the piston rises.

In the basic form of the test, the solution and the apparatus were left at the room temperature.

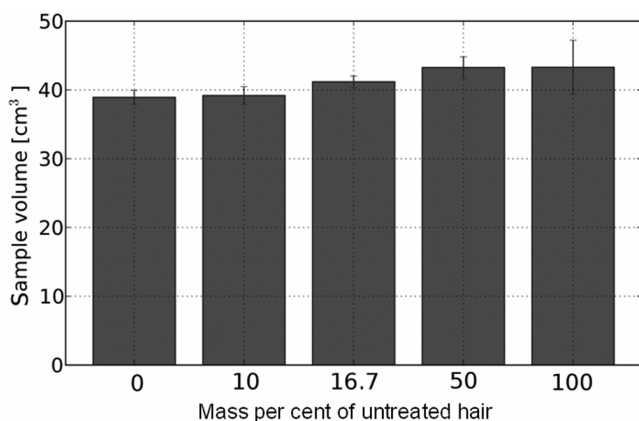

Fig. 3—Test results at room temperature

To change the range of sensitivity of the test the temperature might be increased, as discussed hereunder.

Modification of Test with Increased Temperature

The test was found to be reasonably sensitive only in the range of higher felting propensity. The following modification of the test was introduced to shift the range of the felting propensity that can be distinguished with the test to lower values.

The water solution was prepared at 82 ± 5 °C. The lower part of the tube 1 was wrapped with a heating cable using the power output of 40 W. This arrangement was sufficient to keep the surface of the tube at the stable temperature of 60 ± 2 °C. The rest of the testing procedure was kept the same as described above. This modification can shift (not extend) the range of sensitivity of the test.

Measurement of Felted Sample

The process as described above is sufficient to determine the felting propensity of the material. It is however not sufficient for the whole sample to felt properly. Therefore, the dimensions of the felted body must be measured immediately after the mechanical treatment, since the dimensions of the sample slowly increase as the sample dries up.

Since the felted body is soft and the edge of it might not be clearly distinguishable, it is advisable to measure the height after a standardised load is applied. In this work, the device shown in Fig. 2 was used. A circular plate (10) with the mass of 40 g and diameter of 45 mm was placed on the top of the sample. The movable part of a calliper (4) was carefully lowered to the plate (10). To prevent pressing the sample with the movable part of the calliper, a simple electrical circuit was introduced.

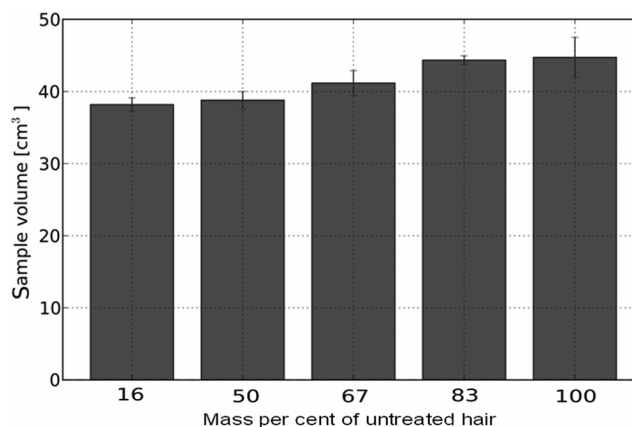

Fig. 4—Test results at elevated temperature

The movable part of the calliper (4) was connected to one pole of a battery, whereas the plate (10) was connected to the other pole. Upon the contact of tip (9) with the plate (10), the LED (5) lights up, signalling the right position of the movable part (4) and thus the height of the sample (11).

This measurement was performed for all three dimensions of the treated sample. It was observed that comparing the dimensions separately was less reproducible than comparing the product of all three measured dimensions. This can be called volume of the sample, under the assumption that the sample is perfectly cuboid. However, this assumption is not entirely correct, it represents a way to cover the situation that one particular dimension is increased at the expense of some other dimension. It can be understood as a kind of geometric mean of the three values.

Results and Discussion

Testing Apparatus and Method

Range of Sensitivity

To test the apparatus, various mixtures of chemically treated top and untreated rabbit hairs were used. Proper mixing was reached during the homogenisation as described above.

Figure 3 shows the results of the testing procedure at the room temperature. Different mixtures of chemically treated and untreated fibres have been tested. The test could reliably reveal the decrease in felting propensity due to the admixture of as little as 17 % of the untreated fibres. However, admixing of 50 % and more of untreated fibres remains indistinguishable.

This drawback is overcome by increasing the working temperature as described earlier. As can be seen in Fig. 4, the sensitivity of the test was very convincing in the range from 50 % to 83 % of

Table 1—ANOVA output table

Parameter	Df	Sum Sq	Mean Sq	F value	Pr(>F)
Operator	1	24.07	24.07	3.592	0.0674
Treatment	1	137.11137	137.1120	4568.39e-05	***
Operator: treatment	1	0.03	0.03	0.005	0.9444
Residuals	31	207.79	6.7	-	-

***Significant p-value.

admixed untreated fibres. However, in the range below 50 % of the untreated fibres, the test is found insensitive. This is probably due to the fact that the increased temperature enhances felting propensity of the samples, moving the range of sensitivity to the region of lower felting propensity.

Repeatability and Reproducibility

To estimate the repeatability and reproducibility, a two-way analysis of variance (ANOVA) method was used^{9,10}. The measurement was performed by two operators (J and T) multiple times on 6.0 g of treated and 6.0 g of untreated hair at the temperature of 21 °C. The “volume” of the resulting cuboid is taken as the dependent variable. The factors possibly affecting the volume are the chemical treatment (two levels: yes and no) and the operator performing the test (J or T). In this method, the following three null hypotheses are tested:

- (i) The mean value of the volumes is independent of the operator performing the test.
- (ii) The mean value of the volumes is independent of the chemical treatment.
- (iii) There is no interaction between the two factors.

The analysis was performed in R system (version 2.14.1) using the function `aov()` of the stats package. The respective mean values are as follows:

Operator J, treated = 38.34 cm³

Operator T, treated = 38.62 cm³

Operator J, not treated = 43.26 cm³

Operator T, not treated = 43.39 cm³.

To indicate that the interaction between the two factors should be analysed, the asterisk (*) operator is used in the definition of the linear model. The proper call of the `aov()` function is

```
analysis <- aov(V ~ operator*treatment)
```

The result can be displayed by `summary()` (analysis). The output is shown in Table 1. The ‘Df’ column shows the degrees of freedom for the respective factors, the ‘Sum Sq’ shows the sum of squared deviations from the mean value of the respective subset, ‘Mean Sq’ shows this sum divided by ‘Df’, the ‘F value’ shows the value of the F statistics. This value is conveniently translated to p-values in the last column. These values quantify the risk of rejecting the three null hypotheses stated above. Following observations were made:

- (i) At the confidence level of 0.05 we cannot safely reject the hypothesis that the outcome does not depend on the operator performing the test, i.e. the test is reproducible.
- (ii) In the second row extremely low p-value is observed, indicating that the test reproducibly shows whether the hair is chemically treated or not.
- (iii) The high p-value in the third row means that the hypothesis of no interaction between the factors cannot be rejected. This further supports the statement that the test is reproducible.

It is shown that the range of sensitivity depends on the temperature. It appears that the combination of two variants – at the room temperature and at the temperature around 60 °C – should be sufficient to cover the whole range of interest for the purpose of industrial felt production. By standardised ANOVA procedure, the test is found repeatable and reproducible.

Acknowledgement

Authors thankfully acknowledge the financial support by the Ministry of Education of the Czech Republic under Grant No. CZ.1.05/2.1.00/03.0086 - CEPLANT and by the Technology Agency of the Czech Republic under Grant No.TA01011356.

References

- 1 Makinson K R, *Wool Sci Rev*, 24 (1964) 34.
- 2 Mercer E H & Makinson K R, *J Text Inst Transact*, 38 (1947) T227. <http://www.tandfonline.com/doi/abs/10.1080/19447024708659307?journalCode=jtit20#.U0eaqXWSwVQ>.
- 3 Lindberg J & Gralen N, *Text Res J*, 18 (1948) 287.
- 4 Speakman J B, Stott E & Chang H, *J Text Inst Transact*, 24 (1933) T273. <http://www.tandfonline.com/doi/abs/10.1080/19447023308661595?journalCode=jtit20#.U0eaxXWSwVQ>.

- 5 Martin A J P & Mittlmann R, *J Text Inst Transact*, 37 (1946) T269. <http://www.tandfonline.com/doi/abs/10.1080/19447024608659277?journalCode=jtit20#.U0eaZ3WSwVQ>.
- 6 Liu Xin & Xungai Wang, *Text Res J*, 77 (2007) 957. <http://trj.sagepub.com/content/77/12/957.short>.
- 7 Blankenburg G, *Wool Sci Rev*, 35 (1969) 24. <http://chemotex.cz/download.php?idx=681&di=15>.
- 8 <http://chemotex.cz/download.php?idx=681&di=15>.
- 9 Chambers J M & Hastie T J, *Statistical Models in S* (CRC Press, Inc. Boca Raton, FL, USA), 1993. <http://www.amazon.com/Statistical-Models-J-M-Chambers/dp/041283040X>.
- 10 Seltman H J, *Experimental Design and Analysis* (Carnegie Mellon University) 2012, 428. <http://www.stat.cmu.edu/~hseltman/309/Book/Book.pdf>.