



Comminution Characters of Fault Zone Rocks and Secure Outcomes in the Blockchain Record-Keeping System for Industrial Applications

Satya Sai Srikant^{1*}, Sachi Pandey¹, Rajendra Prasad Mahapatra¹, Vikas Chouhan² & Raghupatruni Bhima Rao³

¹SRM Institute of Science and Technology, Delhi – NCR Campus, Modinagar 201 204, Uttar Pradesh, India

²Indian Institute of Technology, Roorkee 247 667, Uttar Pradesh, India

³CSIR-Institute of Minerals and Materials Technology, Bhubaneswar 751 013, Odisha, India

Received 14 October 2021; revised 13 June 2022; accepted 21 June 2022

This paper is an attempt to find the energy required for the comminution of fault zone rocks and also to determine the energy required to grind ore from infinite size to the desired particle size in non-traditional approach, for various value additions. The results in the present investigations also confirm about the brittleness test and friability tests, whose values depend on the drop weight and its height for different types of fault zone rock. Also the results of its brittleness tests determine the grindability of fault zone rocks. All the outcome results are then secured with the help of decentralized and immutable record-keeping system using Blockchain technology. The Blockchain network in the present investigations not only allows any users to enhance the performance but also it will secure the experimental outcomes in immutable distributed ledgers through smart contracts to increase transparency between users in a trusted manner.

Keyword: Blockchain network, Bond's work index, Brittleness, Friability test, Grindability, Smart contract

Introduction

Geological history of Odisha dates back to more than 3000 million years ago in Precambrian. The southern portion of the state is covered with the rocks of the Eastern Ghats mobile belt. It comprises mainly granitic suites, Charnokite, Khondalite, etc. Epirogenic movements are marked during the quaternary period, which led to the upliftment of the continental crust and sedimentation under arid and humid climatic conditions resulting in the formation of laterite older delta and newer delta. Laterites of both high and low levels occur extensively in the state, generally as capping over the older formations. The lithologic assemblage is characterized by the cyclic sedimentation of sand and gravel with subordinate clay. Alluvium of recent age occurs in numerous but with narrow disconnected pockets adjoining and it occurs most of the river stream courses throughout the state.¹

The Eastern Ghats of coastal Odisha contains Khondalite rocks. These rocks at some places get weathered and re-deposited as lateriferrous bauxite deposits. During this process, some patches of kaolin clay or lithomarge are formed due to the chemical

weathering process. Such rocks are not useful for the recovery of alumina, and hence such rocks are being excavated along with the bauxite and thrown as waste rocks, but these rocks are very useful for value addition after suitable processing. Interestingly it is observed such rock formations along the fault zone in Khurda Dist., of Odisha. Quarrying of laterite stones along the Sundarpada-Jatni road and Patrapada-Jatni road, Khurda Dist., is very common for boundary wall constructions and low-cost temporary houses. Rock quarry along the fault zones are being used for the basement of roads in rural areas. At present, some of the quarries are abandoned and water-filled and are posing a threat to animals and civilians. In geology, a fault is a planar fracture or discontinuity in a volume of rock across which there has been significant displacement along with the fractures as a result of earth movement.^{1,2}

The two sides of a non-vertical fault are known as the hanging wall and footwall. By definition, the hanging wall occurs above the fault plane where as the footwall occurs below the fault.² This terminology came from mining, the miner stood when working a tabular ore body, with the footwall under his feet as well as with the hanging wall hanging above him.^{2,3} The present paper deals with one of the operating rock quarry Sundarpada -Jatni Road of Khorda district,

*Author for Correspondence
E-mail: satya.srikant@gmail.com

Odhisa state, India. The present rock quarry is along the fault zone. Interestingly the foot wall containing partially weathered laterite-khondalite-lithomerge rocks (soft rock) and the other side the hang wall contain partially weathered laterite-feldspatheic-quartzite rocks (hard rock). The lithomerge rocks are found in a discontinuity in the lithology. These rocks are being used for road basements in rural areas. Since this fault zone contains a huge amount of lithomerge and bauxitic clay, it is a potential resource for high value added filler industries after physical mineral processing methods.

In view of the above, different types of rocks were collected along the fault zone in the present investigation. The present paper deals with the comminution characteristics of these rocks using different comminution unit operations and determines the energy consumption for a grinding rock suitable to industry applications. The literature review reveals that many researchers attempted to determine the work index values for different ore types or rocks and their correlation with other methods of grindability, especially the brittleness tests or friability values.⁴⁻⁸ It was also desired to develop a decentralized and transparent platform based record-keeping system to record each test finding in a decentralized, immutable platform using smart contracts of Blockchain.^{9,10} According to the pre-defined endorsement policies, the endorsement peers verify and approve the transaction's validity. In the used Hyperledger Blockchain environment, a new block was added to the shared distributed ledger chain. This chain is tamper-proof and identical throughout the network. This technology ensures the correctness of every test and stores findings in the distributed ledger of the decentralized system to avoid a single point of failure.¹⁰ Due to the decentralized nature of the Blockchain network, any registered user can store their findings from any location via the Internet. As a result, experimental transparency improves the legitimacy and trustworthiness of the specific rock experimental community and industries around the

world. On the other hand, smart contracts are automatically invoked and executed when an event is triggered based on users' queries, i.e., store and retrieve.

Yarall and his colleague Soyer had investigated about the mechanical rock properties and brittleness which described about the rock resistance measurement to crush because of impact of repeated and random weight drop.¹¹ Many researchers found the relationship among the brittleness, friability value and the various performance parameters of rock properties in literature,¹²⁻¹⁵ but in this present paper, attempts were made to investigate the work index value of different types of rocks such as (a) hard rock sample, (b) medium hard rock sample, and (c) soft rock sample by using different methods of work index to determine the energy requirement for grinding of rock material and its brittleness, friability properties for industrial applications.

Materials and Methods

Raw Materials

A typical operating quarry along the fault zone can be seen in Fig. 1. Typical rock samples collected as raw materials along the fault zone can also be seen in Fig. 2, and in this present investigation, these raw materials samples are categorized as (a) hard rock sample (b) medium hard rock sample and (c) soft rock sample. The collected gravel size samples were screened at 5 mm and 3 mm.

These samples were used for brittleness tests. About 50 Kg samples were collected separately from



Fig. 1 — Operating rock quarry at fault zone along Sundarpada-Jatni Road, Bhubaneswar



Fig. 2 — Geomorphic features of different types of rocks [Circle -sample location]

each rock type for Bond work index tests. The details of these experiments were discussed in the next sections for the Bond work index procedure.

Brittleness Tests

The experimental setup for the brittleness tests of all the selected three variety samples collected from the fault zone separately for measuring the friability value (S₁) as it is shown in Fig. 3. All the samples were passed through at 3 mm and 5 mm screening size. The selected rock sample passing through 5 mm and retained on 3 mm i.e. -5+3 mm size fraction was investigated for fine crushing in order to measure their brittleness tests. Due to this reason, a special type of equipment has been designed, as shown in Fig. 3, for testing the rock strength characteristics. The weight dropped was half a kilogram from the variable heights of 0.8, 1.0, and 1.2 m respectively. The drop weight tests of a minimum three parallel tests were then studied thoroughly in order to measure the friability values with their average values. The friability (S₁) is calculated as given below:

$$F = \frac{\text{Broken weight passes 3 mm (gm)}}{\text{Sample Weight}} \times 100 \quad \dots(1)$$

Thus the friability value S₁ defines about the undersized material percentage that entirely passes through the 3 mm size after grinding. At each fall, the calculation of energy for drop weight is evaluated as shown in Eq. (2)

$$E = m \times g \times h \quad \dots(2)$$

Here E shows the Energy of each fall in Joules for weight drop mass (m in Kg); h denotes height (in m) from where the falls on the sample where as symbol g denotes gravitational force in m/sec².

Bond's Work Index

The samples were prepared separately with stage grinding process so as to pass for 6 mesh sieve. The

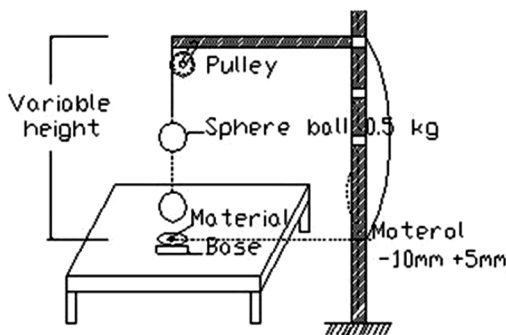

Fig. 3 — Drop weight tests experimental set up

weight of a 700 cc sample was placed in the mill. The sample grinding was investigated in a standard ball mill 300 mm × 300 mm size, as shown in Fig. 4. The steel balls weighing 20.125 Kgs were used for grinding ball mill. The size of steel balls and their numbers used in grinding mill are shown in Table 1.

The weight of the material of the 700 cc volume sample with the balls was charged to the grinding mill and then crushed initially at a frequency of 100 revolutions per cycle. These crushed samples were passed through the test sieve, and the undersize samples were weighed and fresh unsegregated feeds were added to the oversize to bring its weight back to that of the original charge. The number of revolutions required was calculated from the results of the previous period to produce sieve undersize equal to 1/3.5 of the total charge in the mill. The crushing period cycles were investigated, till the total grams of sieve undersize produce per mill revolutions reached steady state. Then the undersize product and circulating load were categorically analyzed, and the last three net grams per revolution (Gbp) produced the ball mill grindability. The test mesh used was 150 microns. The Bond Work index W_i was evaluated from the following equation

$$W_i = 44.5 (P_i)^{-0.23} \times 10 \times (Gbp)^{0.82} [(P_{80})^{-0.5} - (F_{80})^{-0.5}] \quad \dots (3)$$

Here, all the sizes of the samples are defined in microns; F₈₀ shows the size at which the new feed to ball mill passes by 80%; P₈₀ provides the size at which sieve undersize product passes by 80% at the last cycle where as P₁ defines about the opening of the tested sieve size

No. of balls	43	67	10	71	94
Size (mm)	36.83	29.72	25.4	19.05	15.94

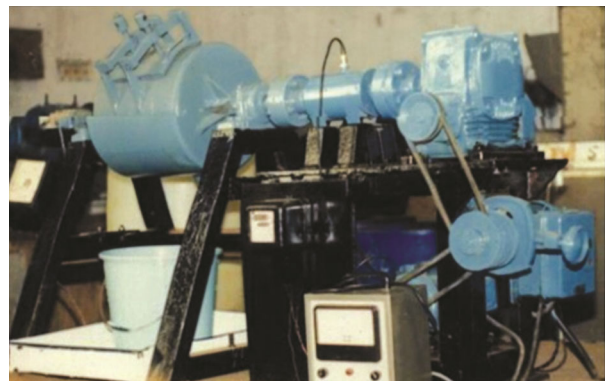

Fig. 4 — Experimental set up for Bond work index tests

Blockchain Network and Smart Contracts

Blockchain is a distributed database that allows users to make, record, and verify any form of transaction safely and transparently.^{10,11} It provides the necessity of centralized control as all the transactions are decentralized and verified in the distributed ledger by the Blockchain database itself. Data in a block cannot be changed after it has been recorded. A Blockchain architecture were designed as shown in Fig. 5 for storing the rocks experimental findings with the record in form of distributed ledgers. Such architecture includes a Blockchain network with multiple peers (P). This network not only connects the users from all over the world on a single trusted but also provides the transparent platform for specific rock-based discoveries. It contains the Blockchain Application Interface (API) from which the users can request to store and view records in the Blockchain network. The API triggered smart contracts specifically developed for storing and retrieving experimental records in the Hyperledger Fabric Blockchain platform, which helps to add the records to the distributed ledgers.

Initially, five structures were defined in Table 2, to collect the required information for creating a particular instance record. The *first* ‘property’

structure was used to initialize the properties of rock, e.g., nature, colour, gravity, density, and passing size. The *second* ‘Rock Descriptions’ structure was defined to store information about the type and properties of rocks. Then the *next* i.e. *third structure*, ‘Sample Details’ was used to collect the sample details. The *fourth structure* ‘Power’ was used to store calculated power in two units. The *final structure* was used to generate the ‘Record’ with the key RID and it includes necessary and required information such as rock description, rock sample details, drop weight height, friability, calculated power, bond work index, and remarks. The final records were preserved in a Blockchain with the key RID.

The record is created and written on the decentralized platform using Smart Contract, as described in Algorithm 1. It receives the stub and a list of arguments as input and returns a corresponding response. This contract first validates the number of input arguments required. The ‘recordId’ was then initialized based on the input arguments. To avoid record redundancy, it returns the error when the record already exists in the blockchain network. Otherwise, it initializes all structure variables using the input arguments. It then marshals the record and stores it in the block corresponding to the record ID by calling the

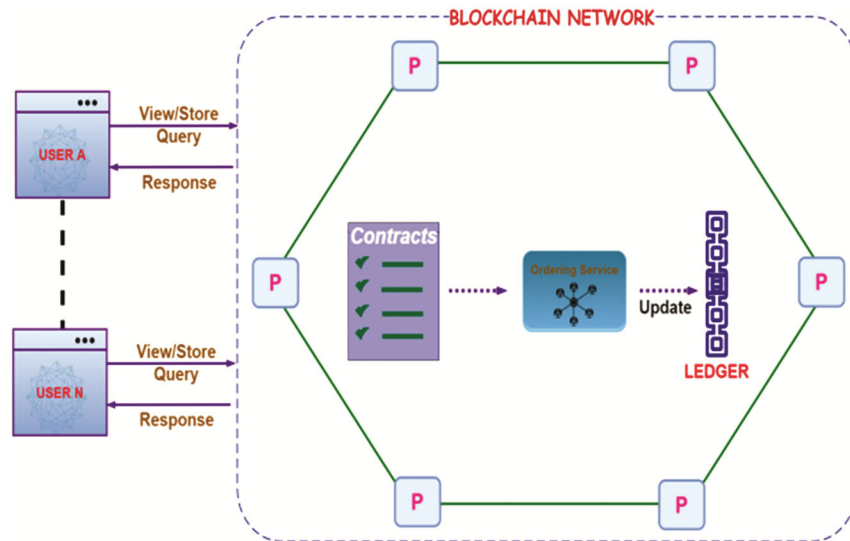

Fig . 5 — Blockchain network architecture for storing rocks tests results

Table 2 — List of Structures

Rock properties with Initialization	Rock Descriptions	Sample Details	Power	Record
String with Nature, Colour, Gravity, Density, Passing Size	Rock Type; Properties	Number of Balls Strings; Size String	Joule; kWh per ton	RID String; Rock Description; Sample Detail; Drop weight Height string; Friability; Index; Power Calculation; Remarks; Output

Put State function. Finally, a successful response with the message "record has been stored" is returned.

Algorithm 2 is a smart contract that describes how to retrieve a stored record from a decentralized blockchain platform. This contract receives stub and arguments as input and returns the retrieved record from blockchain corresponding to the input record identity 'recordId'. First, it invokes the Get State method of the blockchain's world state database to retrieve stored information as a Bytes form (recordAsBytes) if information exists; otherwise, it failed to get state and written an error response. Then the record variable is created to stores the unmarshal information of record As Bytes. Finally, it returns a successful response, including retrieved information.

Algorithm 1 — Created record on decentralized platform

```

Input : stub ChaincodeStubInterface, args []string
Output : Response
1 begin
2   if len(args) != 15 then
3     return Error("Incorrect number of arguments. Expecting 15")
4   end
5   recordId ← args[0]
6   if IsRecordExist(stub, recordId) then
7     return Error("Record " + recordId + "is already exists.")
8   end
9   /* Initializing all the structures */
10  var prop Properties
11  prop.Nature ← InitStructValue(args[2])
12  prop.Colour ← InitStructValue(args[3])
13  prop.Gravity ← InitStructValue(args[4])
14  prop.Density ← InitStructValue(args[5])
15  prop.PassingSize ← InitStructValue(args[6])
16  var rockdesc RockDescriptions
17  rockdesc.RockType ← InitStructValue(args[1])
18  rockdesc.Property ← InitStructValue(prop)
19  var sample SampleDetails
20  sample.NumBalls ← InitStructValue(args[7])
21  sample.Size ← InitStructValue(args[8])
22  var pow Power
23  pow.Joule ← InitStructValue(args[9])
24  pow.kWh_per_t ← InitStructValue(args[10])
25  var record Record
26  record.RID ← InitStructValue(recordId)
27  record.RockDescription ← InitStructValue(rockdesc)
28  record.SampleDetail ← InitStructValue(sample)
29  record.DropWeightHeight ← InitStructValue(args[11])
30  record.FriabilityValue ← InitStructValue(args[12])
31  record.PowerCalculated ← InitStructValue(pow)
32  record.BondWorkIndex ← InitStructValue(args[13])
33  record.Remarks ← InitStructValue(args[14])
34  /* Putting state in block */
35  PutState(record.RID, Marshal(record))
36  /* record has been entered */
37  return Success("record has been stored")
38 end

```

Algorithm 2 — Retrieved stored record from decentralized platform

```

Input : stub ChaincodeStubInterface, args []string
Output : Response
1 begin
2   recordId ← args[0]
3   recordAsBytes, err ← stub.GetState(recordId)
4   if err != nil then
5     jsonResp ← "{ \"Error\": \"Failed to get state for\" + recordId + \"\" }"
6     return Error(jsonResp)
7   end
8   var record Record
9   Unmarshal(recordAsBytes, &record)
10  return Success(recordAsBytes)
11 end

```

Blockchain is now a leading technology in practically for every industry. As a result, one has to adapt such technology in a novel way to create a unique research platform. The proposed blockchain record-keeping architecture connects together all of the rock experimental communities and industries from the world to contribute towards the research community in a transparent manner. This single platform allows people all around the world to contribute their observations and insights.

Results and Discussion

Physical characteristics of rocks

The physical properties of different rocks are given in Table 3. All the samples show the similar physical characteristics. The bulk density of the samples usually varies from 1.1 to 1.4 g/cc where as its true densities vary from 2.88 to 2.9 g/cc. However, these samples exhibit closely differs in nature and colour. The hard rock is compact and un-weathered, and the surface is coated with greenish mass colour. The medium hard rock is moderately brittle and partially weathered with greyish and ferruginous colours. The soft rock is brittle to soft, highly weathered, and looks like white talcum powder colour with variable colour shades of pinkish to ferruginous colours.

Brittleness test

Typical samples of medium hard rock sample used for brittleness samples are shown in Fig. 6. However, brittleness for different types of fault zone rocks samples in any geological location determines about its friability values, ^{4,5,11} which are shown in Fig. 7 and Fig. 8. Typical size analysis data on drop weight tests for medium hard rock type is shown in Fig. 7, and drop weight height on friability values shown in Fig. 8 indicates that with increasing drop weight

Table 3 — Physical and chemical properties of different types of rocks

Properties	Hard rock	Medium hard rock	Soft rock
Nature	Hard compact, unweathered	Moderately brittle, partially weathered	Brittle to soft, highly weathered
Colour	Surface with greenish mass colour	Greyish and ferruginous	White talcum powder colour with pinkish to ferruginous
Specific gravity	2.9	2.89	2.88
Bulk density, g/cc	1.4	1.3	1.1
d ₈₀ , passing size µm [crushed]	2000	1700	1000



Fig. 6 — Typical medium hard rock for drop weight tests

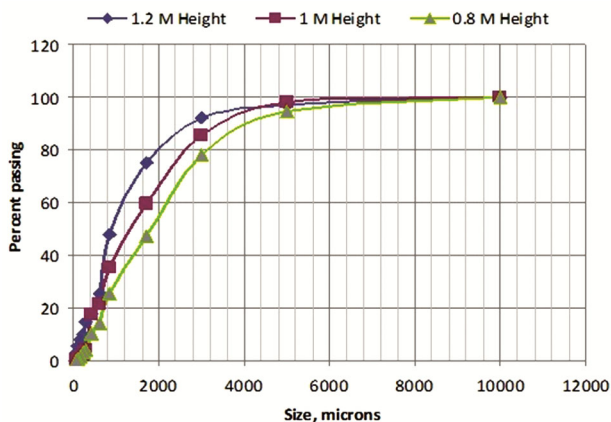

Fig. 7 — Drop weight [0.5 Kg] effect on medium hard rock sample

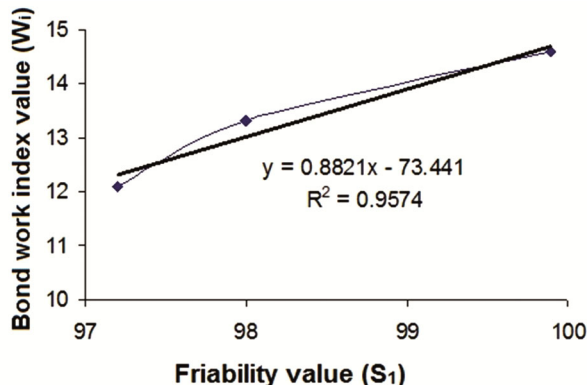

Fig. 8 — The relationship between (S₁) and (W_i)

Table 4 — Effect of drop weight height on breakage properties of medium hard rock

Drop weight height (m)	Friability value (%)	Power calculated (J)	Power calculated kWh/t
0.8	97.2	3.9204	14.11
1.0	98.0	4.9005	17.66
1.2	99.9	5.8806	21.17

Table 5 — Drop weight height [0.8m] effect on breakage properties of different types of rocks

Type of Rock	Power calculated (kWh/t)
Hard	13.32
Medium hard	14.11
Soft	15.90

height, the percentage of fines is increasing along side of the friability values.

The friability value S₁ provides the information about the undersized material percentage, which passes and crosses through 3 mm size after crushing on the base mortar with one weight drop. The average value for a minimum of five to six tests is chosen for finding the value of rock sample S₁. The weight dropped is 0.5 Kg. So, the energy at each fall is 0.5 Kg × 0.8m × 9.81 m/sec² = 3.9204 J (as per Eq. 1). S₁ is the broken weight passes 3mm (gm.)/sample weight (500 gm.) in percentage. The S₁ value for medium hard rock is found to be 97.2%. These values for all types of rocks and drop weight heights are given in Tables 4 and 5.

It is further observed at 1 m height drop weight, the percentage of -3 mm particles produced is 98% by weight, whereas at 1.2 m drop weight height, the percentage of -3 mm particles produced is 99.9% by weight. Accordingly power calculated in joules or in kWh/t for different drop weights of 0.8, 1.0 and 1.2 m heights are 3.9204 J [14.11 kWh/t], 4.9005 J [17.66 kWh/t] and 5.8806 J [21.17 kWh/t] respectively. This data can also be seen clearly from Fig. 9, where the drop weight height vs. energy requirement for brittleness characteristics of rock has been presented. The data clearly indicate that with increasing drop weight height, the energy required to crush the material is also increasing.¹⁹ The effect of drop weight height [0.8m] on breakage properties of

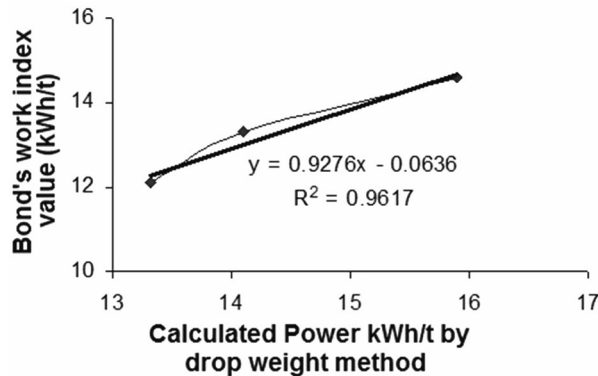

Fig. 9 — Bond's work index for different types of rocks

different types of rocks is given in Table 5. The data given in Table 5 indicate that the hard rock requires 13.32 kWh/t, the medium hard rock requires 14.11 kWh/t and the soft rock requires 15.90 kWh/t. Thus it can be concluded from this data that for any given drop weight height, the breakage properties of rock depend on the hardness. The softer rock requires more energy than the hard rock.

Bond's Work index test

Bond Work index values, kWh/t for different types of rocks, determined as per the Bond, are given in Table 6. It is observed that the work index values, kWh/t is depending on the hardness of the rock. The softer rock needs more energy than the hard rock. In the present investigation, the work index value obtained for hard rock is 12.1 kWh/t. The work index value obtained for medium hard rock is 13.3 kWh/t where as for soft rock, the work index value obtained is or 14.6 kWh/t. The work index values obtained as per the Bond for different types of rocks indicate that the softer rock needs more energy to grind the material for industrial applications. In the comminution process, relatively, the soft rock makes the cushioning effect either in the crushing circuit or in the grinding mills, by which the grinding performance will be affected.

Relationship of Work index (W_i) and friability value (S_1)

The relationship between friability value (S_1) and Bond work index value (W_i)⁹⁻¹¹ is shown in Fig 8. The values shown in Fig. 9 indicate that the friability value varies inversely related with the Bond's Index value. It is known that the Bond grindability test is used widely in rolling mill and tumbling ball mill in material and mineral processing industries.¹²⁻¹⁵ Also it provides constant grindability factor with longer life period. For this reason, it is essential to determine a

grindability value of materials alternatively with a simple test apparatus that gives quick results. The correlation found between the friability value (S_1) and Bond's work index (W_i), as shown in Fig. 8, were $R^2 = 0.9574$; $y = -0.8821x - 73.441$ and where as correlation found between the Bond's work index (W_i) and power required with drop weight method as shown in Fig. 9 were $R^2 = 0.9617$; $y = 0.9276x - 0.0636$.

Thus it was concluded that the Bond's grindability determination method were time consuming and provides constant material grindability value even after many grinding periods.¹⁵⁻¹⁷ The brittleness test provides the faster and better process, hence its friability value was obtained in much lesser time. Smaller grains were relatively crushed and ground in brittleness tests, whereas in Bond's index tests, it involves of grinding from coarse to fine grain samples. It may be again noted that the brittleness test was performed on compact and simple testing equipment. Due to this reason, work index results might not be very close to the brittleness test results. However, brittleness values could be used for relative comparisons with work index values. Thus the grindability of fault zone rocks could also be performed by the simple brittleness tests.¹⁸⁻¹⁹

Performance metrics of smart contracts

The Blockchain implementation work was validated by using Hyperledger Caliper Benchmark testing to ensure that the deployed Smart Contracts (SC) perform as expected. The transaction latencies, success and failure rates which were achieved throughput in terms of transactions per second (tps), in order to evaluate the performance of both smart contracts. Two modules were successfully tested with 100 and 200 transactions with 50 and 100 transactions per second respectively with the Blockchain platform. The 'Insert Record' contract stores the record in the Blockchain, while the 'View Record' contract retrieves the stored record from the Blockchain. The screenshot of the caliper benchmark performance metric of deployed smart contracts is shown in Table. 7. It was observed that both contracts run successfully for 100 and 200 transactions, respectively, with no failures or timeouts. The rate control type was set to a fixed rate with 50 tps and 100 tps in the configuration. As a result, the sending rate was around 50 for the first two rounds of contacts and around 100 for the next two rounds. Besides, the contact's latencies are measured in seconds; however,

Table 7 — Smart contracts performance summary

Name	Succ	Fail	Send Rate (TPS)	Max Latency (s)	Min Latency (s)	Avg Latency (s)	Throughput (TPS)
Insert Record	100	0	51.2	29.98	1.12	13.34	4.0
View Record	100	0	51.1	0.10	0.01	0.04	50.8
Insert Record	200	0	100.9	29.72	1.49	16.24	4.2
View Record	200	0	100.8	0.90	0.01	0.28	100.2

```

2021.09.15-17:17:54.534 info [caliper] [report-builder]
2021.09.15-17:17:54.536 info [caliper] [report-builder]
### All test results ###
2021.09.15-17:17:54.552 info [caliper] [caliper-flow] Generated report with path /hyperledger/caliper/workspace/report.html
2021.09.15-17:17:54.656 info [caliper] [message-handler] Handling "exit" message
2021.09.15-17:17:54.656 info [caliper] [message-handler] Handling "exit" message
2021.09.15-17:17:54.657 info [caliper] [round-orchestrator] Benchmark finished in 109.528 seconds.
Total rounds: 4. Successful rounds: 4. Failed rounds: 0.
Network configuration attribute "caliper.command.end" is
not present, skipping end command
2021.09.15-17:17:54.658 info [caliper] [caliper-engine] Benchmark successfully finished
2021.09.15-17:17:54.659 info [caliper] [cli-launch-master]

```

the record creation contact requires a few extra seconds due to additional operations such as information collection and marshaling. It is because of throughput is affected by latency, the throughput for record insertion is around 4 tps. The viewing record throughputs, on the other hand, are nearly equal to the sending rate. According to the performance, the retrieving modules are faster than the writing modules.

Conclusions

The present paper provides the comminution characteristics of fault zone rocks and secure experimental outcomes for industrial applications across the decentralized environment using Blockchain technology. The results with Blockchain architecture provide specific rock experimental comminution characteristics in a single platform to share their findings and expand their network to contribute transparently. The results were drawn from Brittleness tests and Bond's work index values for different typical fault zone rock samples such as hard rock, medium hard rock, and soft rock samples based on their physical properties, work index, friability and their brittleness properties. It has been observed that the physical properties of different rocks are almost similar. However, these samples exhibit closely differs in nature and colour. The drop weight tests for medium hard rock type reveal that the percentage of fines as well as the friability values is increasing with drop weight height. It is also observed that for any given drop weight height, the breakage properties of rock depending on the hardness. The softer rock requires more energy than

the hard rock. There is a correlation between Bond's work index and the value of friability (S_1), which varies proportionally. Similarly, power required also varies proportionally with Bond's work index. The Work index values could be one of the relative tests for the brittleness properties. The grindability of fault zone rocks was determined with simple brittleness tests.

Thus, the drop weight tests can be considered for determination of energy requirement, which is as compared to the traditional Bond work index. Such fault zone rock defect investigations can be very much useful in Red Mud, Red Sediment topography, E-waste technology etc for recovering valuable elements and compounds from various materials and mineral processing, which will be future scope of studies in above mentioned area.

References

- Mahalik N K, Sahoo H K, Hota R N, Mishra B P, Nanda J K & Panlgrahi A B, Society of geoscientists and allied technologists, geology and mineral resources of Orissa, Bhubaneswar, 3rd Edition, 2006 370–371 <http://www.geosocindia.org/index.php/jgsi/article/download/81296/62722>
- Faults jpb (2020) 97-123 <https://www.files.ethz.ch/structuralgeology/JPB/files/English/3faults.pdf>
- Tingley J V & Pizarro K A, Travelling America's loneliest road: A geologic and natural history tour, *Nevada Bureau of Mines and Geology*, 1 (2000) 132–140.
- Ozkahraman H T & Sirin M, The use of brittleness test in determination of grindability and crushing resistance of rocks and marbles, *7th Innovations in mineral and coal processing* (İstanbul, Turkey) 15–17 September, 1998.
- Ozkahraman H T, A meaningful expression between bond work index, grindability index and friability value, *Min Eng*, 18 (2005) 1057–1059.

- 6 Sener S & Ozbayoglu G, Effect of heat treatment on grindability of ulexite, *7th Innovations in mineral and coal processing* (Istanbul, Turkey) 15–17 September, 1998.
- 7 Bond F C, Crushing and grinding calculations, *CIM Bulletin*, **47** (1954), 466 – 472.
- 8 Bond F C, Crushing and grinding calculations part-i, *British Chem Eng*, **6** (1961) 378–385.
- 9 Androulaki E, Artem B, Vita B, Christian C, Christidis K, Angelo D C, David E, Murthy C, Srinivasan M, Sethi M, Singh G, Smith K, Sorniotti A, Marko V, Chrysoula S, Sharon W C, Jason Y, Binch N, Yacov M, Gennady L & Ferris C, Hyperledger fabric: a distributed operating system for permissioned blockchains, *Proc of the 13th EuroSys Conf* (Portugal) 2018, 1–15.
- 10 Nofer M, Peter G, Oliver H & Dirk S, Blockchain, *Bus Inf Syst Eng*, **59** (2017) 183 –187.
- 11 Yarali O & Soyer E, The effect of mechanical rock properties and brittleness on drillability, *Sci Res Essays*, **6** (2011) 1077-1088. DOI: 10.5897/SRE10.1004
- 12 Safonov A I, Kuznestova N V, Lukyanov I V, Panov A V, Suss A G & Damaskin A A, Effect of process parameters on the grindability and Bond index of bauxites and alumina-bearing ore, *Metallurgist*, **53** (2009) 57–63.
- 13 Mucsi G, Fast test method for the determination of the grindability of fine materials, *Chem Engg Res Des*, **86** (2008) 395–400.
- 14 Magdalinovic N, Abbreviated test for quick determination of Bond's work index. *J Mines Met*, **39** (2003) 1–4.
- 15 Wanzhong Y, Yuexin H, Xinachao W, Zhitao Y & Fujia Y, Research on selective grinding behaviours of bauxite, *Min Sci Technol*, **2** (2004) 577–581.
- 16 Levin J, Observations on the Bond standard grindability test, and a proposal for a standard grindability test for fine materials, *J South Afr Inst Min Metall*, **89** (2003) 13–21.
- 17 Haese U, Scheffler P, Fasbender H, Mahlbarkeitsprüfung und rohrmühlenauslegung bei zementrohstoffen (Translated as *Grindability testing and tube mill design for cement raw mat*), *Cement-Kalk-Gips*, **8** (1975) 316–324
- 18 Altindag R, Correlation of specific energy with rock brittleness concepts on rock cutting. *J South Afr Inst Min Metall*, **4** (2003) 163–172.
- 19 Rout S, Soni R K & Eswaraiah C, Comminution studies of carbonite rock: evaluation of energy and breakage kinetics, *74th Annual Session of Indian Inst of Chem Eng* (CSIR-IMMT, Bhubaneswar) 1–10 December 2021